

Hot Water
to House

VOL 8



THE REHAB GUIDE

Pump

Air Handler

HVAC/PLUMBING



PATH (Partnership for Advancing Technology in Housing) is a new private/public effort to develop, demonstrate, and gain widespread market acceptance for the “Next Generation” of American housing. Through the use of new or innovative technologies the goal of PATH is to improve the quality, durability, environmental efficiency, and affordability of tomorrow’s homes.

Initiated at the request of the White House, PATH is managed and supported by the Department of Housing and Urban Development (HUD). In addition, all Federal Agencies that engage in housing research and technology development are PATH Partners, including the Departments of Energy and Commerce, as well as the Environmental Protection Agency (EPA) and the Federal Emergency Management Agency (FEMA). State and local governments and other participants from the public sector are also partners in PATH. Product manufacturers, home builders, insurance companies, and lenders represent private industry in the PATH partnership.

To learn more about PATH, please contact:

PATH
Suite B 133
451 7th Street SW
Washington, DC 20410
202-708-4250 (fax)
e-mail: pathnet@pathnet.org
website: www.pathnet.org

DISCLAIMER

The statements and conclusions contained in this report are those of Steven Winter Associates, Inc. and do not necessarily reflect the views of the Department of Housing and Urban Development. Steven Winter Associates, Inc. has made every effort to verify the accuracy and appropriateness of the report’s content. However, no guarantee of the accuracy or completeness of the information or acceptability for compliance with any industry standard or mandatory requirement of any code, law, or regulation is either offered or implied. The products listed in the report are included only as examples of some available products. No endorsement, recommendation, or evaluation of these products or their use is given or implied.

HVAC/PLUMBING

VOLUME 8 OF THE REHAB GUIDE

TABLE OF CONTENTS

FOREWORD **3**

1. INTRODUCTION **4**
2. HVAC DESIGN & ENGINEERING **6**
3. DISTRIBUTION SYSTEMS **11**
4. HEATING **19**
5. COOLING **25**
6. HEAT PUMPS **31**
7. INDOOR AIR QUALITY **36**
8. CONTROLS **42**
9. FIREPLACES & CHIMNEYS **47**
10. DOMESTIC HOT WATER HEATING **54**
11. PLUMBING DESIGN & ENGINEERING **61**
12. WATER SUPPLY & DISTRIBUTION SYSTEMS **63**
13. DRAIN, WASTE, & VENT SYSTEMS **67**
14. FUEL SUPPLY SYSTEMS **73**
15. APPLIANCE VENTS & EXHAUSTS **75**
16. FIRE PROTECTION SYSTEMS **78**

APPENDIX: PROFESSIONAL ASSOCIATIONS & RESEARCH CENTERS **81**

Prepared for:
U.S. Department of Housing
and Urban Development
Office of Policy Development
and Research

Prepared by:
Steven Winter Associates, Inc.
Building Systems Consultants
Norwalk, CT

Contract DUI00C000005956
August 1999

CREDITS

STEVEN WINTER ASSOCIATES, INC. STAFF MEMBERS
WHO WERE INSTRUMENTAL IN THE DEVELOPMENT AND
PRODUCTION OF THIS GUIDEBOOK INCLUDE:

Steven Winter
Principal-in-charge

Michael J. Crosbie, Ph.D., RA
Project manager and Editor-in-chief

Diane Griffiths and Donald Clem
Project team members

Christoph Weigel and Masaki Furukawa
Illustrators

U.S. DEPARTMENT OF HOUSING AND URBAN DEVELOPMENT
OFFICE OF POLICY DEVELOPMENT AND RESEARCH, AFFORDABLE
HOUSING RESEARCH AND TECHNOLOGY DIVISION

David Engel
Director

Nelson Carbonell
Senior architect

GUIDEBOOK DESIGN

Andrew P. Kner
Art Director

Michele L. Trombley
Assistant Art Director

Elizabeth Rosen
Symbols

FOREWORD

President Clinton recognizes that research and technological innovation are crucial if America is to meet its affordable housing needs. In 1998, the President introduced a major new initiative: The Partnership for Advancing Technology in Housing (PATH). This initiative brings together leaders from the home building, product manufacturing, insurance, and financial industries, as well as representatives from federal agencies, to spur housing design and construction innovations.

Thanks to the development of new machinery and materials and the creation of new technologies and techniques, the construction industry has made great progress. But a breakthrough material, a labor-saving tool, or a cost-cutting technique is only valuable if it is widely adopted, which means the construction industry must first become aware of these new developments.

The Department of Housing and Urban Development can help. We have commissioned a set of guidebooks that will present state-of-the-art techniques, materials, and technologies for housing rehabilitation. This volume, *HVAC/Plumbing*, is the eighth of nine guidebooks—known collectively as *The Rehab Guide*—that will appear over the next few years.

We are presenting these guidebooks because, like research and technological innovation, housing rehabilitation is an essential component of America's commitment to provide affordable housing. I am pleased to present this important publication in the hope that it will become a valuable resource that leads to affordable, high quality rehabilitation, and thus to better housing for all Americans.



Andrew Cuomo, Secretary
U.S. Department of Housing and Urban Development

This series of guidebooks has been produced by the U.S. Department of Housing and Urban Development to keep the design and construction industry abreast of innovations and state-of-the-art practices in home rehabilitation. As is too often the case, innovative techniques, materials, technologies, and products are slow to make their way into accepted practice. It is evident that such innovations will not advance unless the industry is made aware of them and they are tested. *The Rehab Guide* is intended to accelerate this process by informing builders, architects, engineers, and other housing rehabilitation professionals about such innovations and state-of-the-art practices.

The Rehab Guide was also prompted by the lack of a comprehensive publication to make the design and construction industry aware of innovative and cost-saving developments in housing rehabilitation. Professional trade magazines, conferences, and trade shows offer some dissemination of this information, but they are rarely focused exclusively on housing rehabilitation, as this series is, nor are they comprehensive.

FOCUS OF THE REHAB GUIDE

The focus of this series is on housing rehabilitation, which is different than home improvement. Rehabilitate means “to restore to good condition,” not necessarily to improve to a state that is significantly different than the original. This is a fine line, but it distinguishes this series from “home improvement” books written for the amateur. *The Rehab Guide* focuses on building technology, materials, components, and techniques rather than “projects” such as adding a new room, converting a garage into a den, or finishing an attic. Nor is *The Rehab Guide* intended to be a “diagnostic” tool; a number of such books are already available to the industry.

The content for this guidebook, *HVAC/Plumbing*, has been gathered from professionals in the housing rehabilitation field; manufacturers and suppliers of innovative technologies, materials, components, tools, and equipment; trade shows, conferences, reports, and publications considering such issues; trade organizations; and building research centers.

A NOTE ON SOURCES

A variety of excellent resources exists for information on heating, ventilating, and air-conditioning (HVAC) and plumbing systems and issues. *This Old House Heating, Ventilation, and Air Conditioning*, published by Little, Brown and Company, is a comprehensive book on HVAC and water heating system alternatives. *Plumbing a House*, published by The Taunton Press, is an excellent source for information on plumbing systems. Monthly publications of interest include the *Energy Design Update*, *Environmental Building News*, *Journal of Light Construction*, *Home Energy*, *Old House Journal*, *This Old House*, and *Traditional Builder*.

Helpful information is also accessible via the Internet. Most equipment manufacturers and monthly magazines have Web sites where specific product information and past articles can be retrieved. The Department of Energy provides a wealth of information on energy conserving techniques and technologies at www.eren.doe.gov/consumerinfo/.

LEAD PAINT HAZARD

The hazard of lead paint in houses constructed before the 1980s is not discussed in the *The Rehab Guide* because there is extensive material available from HUD, the Environmental Protection Agency (EPA), and other sources. However, if you are a non-profit or rehab contractor rehabilitating pre-1978 housing for sale or rent, or if you are a homeowner rehabilitating a home for your own use, you are strongly urged to have the home tested for lead paint. This is especially critical if the home will be occupied by young children. Very small

amounts of lead in paint or dust can poison children if swallowed or inhaled, causing damage to the brain and other organs, resulting in health problems and reduced intelligence. If lead paint is found, it is critical that all rehabilitation be done very carefully to reduce the possibility of lead poisoning to you or your workers. Proper work practices will minimize the risk of spreading lead contamination and increasing occupant exposure.

One of the best and most recent sources on this subject is the HUD publication, “Lead Paint Safety: a Field Guide for Painting, Home Maintenance, and Renovation Work.” Another good publication is the EPA brochure, “Reducing Lead Hazards When Remodeling Your Home.” Both can be obtained by calling the National Lead Information Center at 800-424-LEAD or by downloading from the web site of the HUD Office of Lead Hazard Control, www.hud.gov/lea. A very comprehensive source is the HUD publication, “Guidelines for the Evaluation and Control of Lead-Based Paint Hazards in Housing,” which gives guidance on controlling lead hazards, lead paint and rehab work, risk assessment, monitoring, inspections, resident and work site preparation, worker protection, and routine building maintenance. This publication is available through HUD-User; you can also download a copy of this document from the HUD web site at: www.hud.gov:80/lea/learules.html.

HUD has new regulations on lead-based paint hazards in federally owned housing and housing receiving federal assistance. If you will be using HUD funds for rehabilitation through grants, insurance, or other types of assistance, then there are protective procedures that must be followed. The Occupational Safety and Health Administration web site at www.osha.gov has information on worker protection requirements. In addition, many states and localities have their own rules regarding lead-based paint, which should be followed when undertaking rehabilitation.

HOW THE GUIDE IS ORGANIZED

Nine volumes will eventually make up *The Rehab Guide* in its entirety, and they are listed on the back cover of this volume. Each one is devoted to distinct elements of the house, and within each volume is a range of issues that are common to that element of home rehabilitation work. This volume, for example, covers topics from new piping materials for the repair of an existing plumbing system to the criteria for selection of an entirely new central heating system. Each volume addresses a wide range of techniques, materials, and tools, and recommendations based on regional differences around the country. Throughout *The Rehab Guide*, special attention is given to issues related to energy efficiency, accessible design, and sustainability.

The Rehab Guide is written and presented in a format intended for easy use. The spiral bound volumes open flat so that they can be easily photocopied, and they can be assembled and stored in a single three-ring binder. Within each volume, drawings, photos, and other graphic materials supplement written descriptions of a broad range of items: state-of-the-art and innovative building technology, products, materials, components, construction and management techniques, tools, equipment, software—virtually any and all items that make housing rehabilitation more efficient in terms of cost and time. While the content focuses on present technologies and techniques that are currently part of the house-building industry, *The Rehab Guide* also includes information on materials, products, and procedures from other construction sectors (such as commercial, industrial, institutional) that are relevant to housing rehabilitation.

The information is organized in different sections according to rehab subjects, and under headings that make this book easy to understand. “Essential Knowledge” gives the reader a basic overview of the important issues related to the section heading. Next, “Techniques, Materials, Tools” presents state-of-the-art and innovative approaches to accomplishing the work. Each entry is explained in detail, including its advantages and disadvantages. This makes it easy for readers to compare approaches and choose the one that is most applicable to their particular project. By design, the “Techniques, Materials, Tools” section is an overview, not a detailed description of implementation. “Further Reading” lists the valuable resources relevant to the subject that readers can go to for more detailed information. Finally, “Product Information” provides names and addresses of manufacturers of products, materials, systems, and components mentioned in the text so that more information can be obtained. By virtue of their being listed here, such products are not necessarily being recommended; their existence and availability are being brought to the reader’s attention. New products should be carefully evaluated in the field as to their performance. The product lists are not necessarily comprehensive, and we encourage readers to bring new materials and products to our attention to be included in later editions of *The Rehab Guide*.

2

HVAC DESIGN & ENGINEERING

2.1

HVAC SYSTEMS OVERVIEW

Heating, ventilation, and air-conditioning (HVAC) systems that are properly operating and appropriate for the home are critical for the comfort and safety of the home occupants. Richard Trethewey of “This Old House” states that the home’s HVAC systems and plumbing set the foundation on which the family’s physical comfort and health depend. Their economic well-being is not only affected by the initial purchase price, but, perhaps more importantly, by the cost of operating and maintaining the systems.

What constitutes an HVAC system is a function of the home, the climate, and the occupants. It is safe to say that all homes have a heating system of some kind, but it is only over the last 20 years that summer air conditioning beyond opening windows became prominent. In 1970, about one-third of new single family homes had central air conditioning; the figure is now over three-quarters. And, the practice of installing mechanical ventilation systems has only matured in the last 10 years with the emphasis on tighter homes and high-efficiency equipment. Today’s HVAC systems can include smart controls, air filtering, humidification and/or dehumidification (Fig. 1).

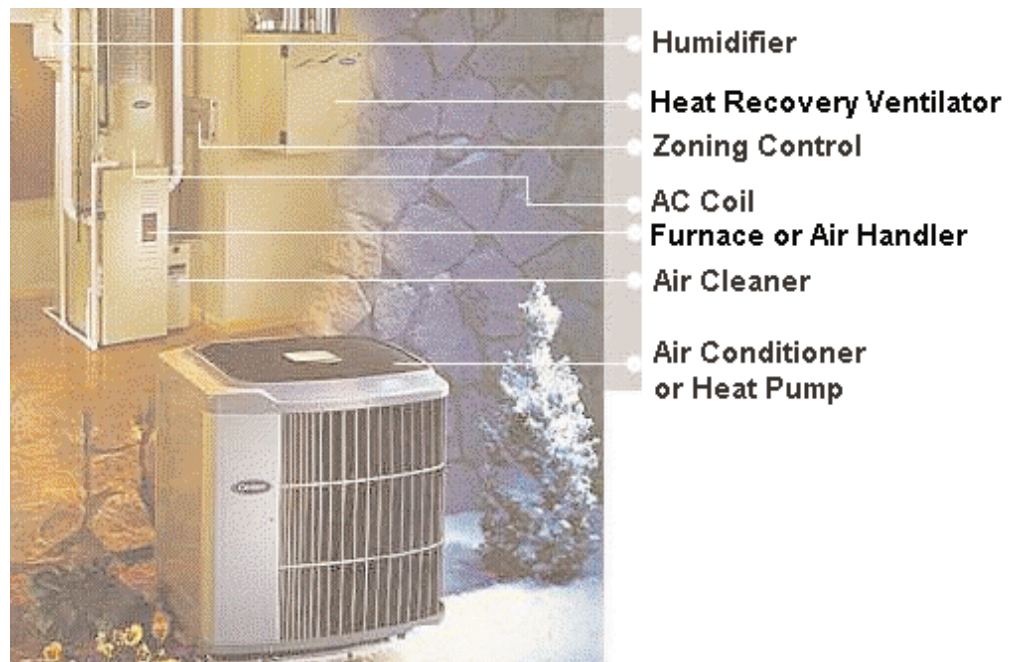

FIGURE 1

HVAC SYSTEM COMPONENTS

When evaluating the rehabilitation needs of a home's HVAC system, the appropriateness of the current *type* of system for meeting the expectations of today's home occupants needs to be considered. They expect to be comfortable in the winter and summer without paying exorbitant energy bills. While a home with electric baseboard heating and passive cooling (i.e. natural ventilation, shading, etc., with no equipment) was fairly common and acceptable 20 years ago, the high winter electric bills due to the increased cost of electricity and poor level of comfort during the summer have diminished its popularity significantly. Even if the baseboard system is in good operating condition, it may be appropriate to consider its replacement.

If it is determined that the type of system is appropriate, the system performance must then be considered. Are there opportunities to improve the performance of the existing system or is it a wiser decision to simply replace the old system with a newer one? Generally speaking, if the heating system equipment is more than 15 years old or the heat pump or air conditioner is more than 10 years old, it should probably be replaced. The energy savings with the higher efficiency equipment available today will pay for the new equipment within a few years. The typical new gas furnace sold in 1975 had an efficiency of 63 percent; by 1988, the typical efficiency had increased to 75 percent; and, in 1997, 86 percent of the furnaces shipped had efficiencies greater than 80 percent. Nevertheless, replacement is not always the answer and there are a number of alternatives for rehabilitating the existing system.

This guideline will review the attributes of many alternatives for rehabilitating HVAC systems. It discusses the advantages and disadvantages of various modifications to existing systems as well as equipment technologies which may be considered for supplementing or replacing the existing system.

As a final note before moving into the discussion of alternatives, it is critically important to understand how HVAC systems interact with other systems throughout the home. A decision concerning the kitchen range exhaust vent can cause the gas furnace to backdraft. Under certain circumstances, an attic ventilator can increase cooling loads rather than decrease them by drawing conditioned air up through the ceiling. When the old natural-draft furnace is replaced with a closed-combustion system, the home's pressure and infiltration rate will be altered, and, as a result, its indoor air quality. Much of the interaction of these systems revolves around the pressurization and depressurization of spaces. Lack of consideration for the effects of various devices on home pressure can result in costly excessive infiltration, damaging condensation in walls, or dangerous levels of carbon monoxide in the home. These issues have been enhanced by today's construction and insulation practices which make homes tighter and therefore easier to pressurize or depressurize. It is important to understand and consider the whole-house implications of each system modification. Contractors who are narrowly focused on a particular trade often do not take all of the interactions within the house into consideration.

FURTHER READING

Building Energy Efficiency, U.S. Congress, Office of Technology Assessment, U.S. Government Printing Office, May 1992.

This Old House Heating, Ventilation, and Air Conditioning, Richard Trethewey with Don Best, Little, Brown and Company, 1994.

Understanding Ventilation, John Bower, The Healthy House Institute, 1995.

2.2

REPLACEMENT SYSTEM SIZING

In many instances, the decision will be made to replace the existing heating and cooling system rather than rehabilitate it. The old system may be well beyond its expected life. Many newer systems are more efficient and can quickly pay for themselves in reduced energy bills. The availability of fuels may have changed (e.g., natural gas may now be available) since the system was originally designed and installed.

If the old heating and/or cooling system in the house being rehabilitated is beyond retrofitting and needs to be replaced, there are two primary reasons why it should not simply be replaced with another system of the same size. The old philosophy of “bigger is better” no longer applies. Systems were traditionally oversized, causing them to cycle on and off frequently. Cycling that results from oversizing is inefficient and hard on the equipment. Also, rehab work may also include the addition of more or better insulation, and better performing windows and doors. This will reduce the heating and cooling loads and allow for a smaller capacity system to be installed.

A design load analysis should be conducted to determine the current heating and cooling capacity needs. There are various methods and levels of sophistication for performing these analyses.

Most equipment vendors are equipped with worksheets or computer software to estimate the appropriate size of the system for the home. They will typically perform a sizing calculation as part of the sales process. While such a service from the dealer is available at no cost, it should be remembered that the dealer is selling equipment, not efficiency. Methods are often over-simplified with factors of safety built in, resulting in over-sized equipment. An alternative is to size the system yourself. There is a multitude of books available that provide instructions, data tables, and examples for performing system sizing calculations. It is recommended that calculations be performed more than once with different methods and sources to provide confidence in the results. While sizing the system may cost a modest amount of time, lack of experience by the novice estimator may result in mistakes. Basic estimating techniques may also not properly account for unique aspects of the home. Another alternative is to hire a consultant to size the system. Professional energy specialists and auditors can evaluate the home and provide recommendations on the size and type of equipment. The advantage here is the benefit of an experienced professional who is focused on energy efficiency, but consulting fees may be hefty.

FURTHER READING

Cooling and Heating Load Calculation Manual, American Society of Heating, Refrigerating and Air-Conditioning Engineers, Inc., 1791 Tullie Circle, N.E., Atlanta, GA 30329, 404-636-8400.

Consumers' Directory of Certified Efficiency Ratings for Residential Heating and Water Heating Equipment, Gas Appliance Manufacturers Association.

Directory of Certified Unitary Products, Air Conditioning and Refrigeration Institute, 4301 North Fairfax Drive, Suite 425, Arlington, VA 22203; 703-524-8800.

Residential Load Calculation Manual J, Air Conditioning Contractors of America, 1712 New Hampshire Ave., NW, Washington, DC 20009; 202-483-9370.

Simplified Design of HVAC Systems, William Bobenhausen, New York: John Wiley & Sons, Inc. 1994.

2.3

ENERGY SOURCES

ESSENTIAL KNOWLEDGE

The most common energy sources for residential use are natural gas for space and water heating and electricity for cooling. Other heating energy sources include electricity, oil, propane, and the sun. In a few instances, wood or coal may even be the primary heating fuel. Natural gas is a potential energy source for cooling as well.

The most appropriate fuel choice for a particular home depends on its availability, price, and the climate. Some of these factors may have changed since the home was built and the fuel choice that was made then may not be the most appropriate choice now. Natural gas, a popular choice now, was not read-

ily available prior to World War II and embargoes were placed on new gas services for a period in the 1970s. Consult the local utilities to determine the availability and rate schedules for the energy alternatives. In most instances, the primary energy sources of electricity, natural gas, and oil should be considered. Old coal-fired systems should be converted to a more-efficient and cleaner fuel alternative such as oil or gas. Various energy sources are discussed below.

TECHNIQUES, MATERIALS, TOOLS

1. ELECTRICITY AS AN ENERGY SOURCE.

In regions with a mild heating season, electricity may be the most appropriate fuel for heating and cooling needs. It is the most logical choice for cooling and, if heating loads are small, any higher cost of electricity will not be a severe penalty. And, in some areas such as the Northwest where hydroelectric plants provide much of the electricity, it is quite economical. In the case of electric air conditioners and heat pumps, electricity is not used directly as an energy source but indirectly to pump heat from one location to another. For heat pumps in the heating mode, the energy source is the sun warming the air for air-source heat pumps and ground for ground-source heat pumps.

ADVANTAGES: Electric resistance heating systems are inexpensive to install, reliable, quiet, and clean. Electric air conditioners are the most common type of mechanical cooling. Electric heat pumps can serve both heating and cooling needs.

DISADVANTAGES: Generally the most expensive fuel choice. Service to home may need to be upgraded. Electric resistance heating (not heat pumps) is prohibited by code in some areas.

2. NATURAL GAS AS AN ENERGY SOURCE.

In most heating-season dominated climates, natural gas is the fuel of choice for space and water heating needs. The residential space heating market shares for natural gas are 59%, 72%, and 48%, in the West, Midwest, and Northeast, respectively. Most of the country's gas processing plants are located in six states: Texas, Louisiana, Oklahoma, Wyoming, Kansas and New Mexico. Canada is another significant source. The use of natural gas as a heating fuel surged with the post-World War II construction of thousands of miles of pipeline for transportation (Fig. 2). Transportation costs still make up a large portion of the consumer's price for gas. Major investments in the pipeline system during the 1980s and early 1990s improved the supply to areas in the Northeast, West Coast and Florida. With the deregulation of the gas industry, gas prices fell approximately 50% from 1985 to 1991. Market competition has led to innovation and advances in technology for the exploration, extraction, and transportation of natural gas.

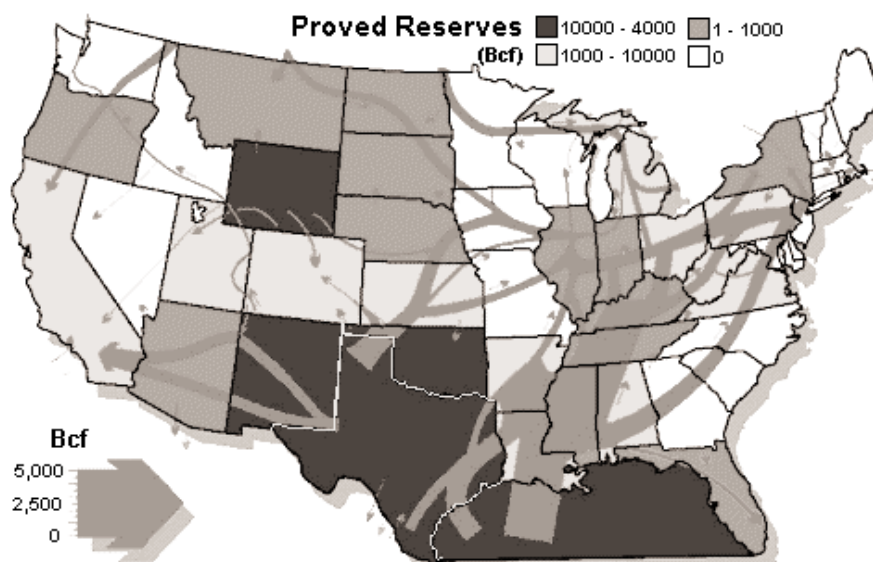

FIGURE 2

MAJOR NATURAL GAS PIPELINES

ADVANTAGES: Generally the least expensive fuel aside from solar energy. No storage tank is required.
DISADVANTAGES: Initial installation cost may be high if gas is not already supplied to the home. Not available in all areas.

3. OIL AS AN ENERGY SOURCE.

Oil is commonly used for heating in cold climates where natural gas is not readily available. It is typically more expensive than gas unless located near a port or refinery or at the end of the natural gas pipeline. The Northeast U.S. is located at the end of the gas pipeline and gas is not available throughout the region. Heating loads are significant and electricity is expensive. Thus, oil has a 36% market share according to the 1993 census.

ADVANTAGES: Generally less costly than electricity.

DISADVANTAGES: Potential for supply shortages and dramatic price fluctuations. Storage tank required with associated environmental concerns and regulations (underground tanks, soil contamination, etc.).

4. PROPANE AS AN ENERGY SOURCE.

Propane, or liquid petroleum gas (LPG), is typically an alternative when electricity is unattractive (usually because of price) and natural gas is not available. Propane comes from natural gas processing and crude oil refining and approximately 85% of the country's supply is produced domestically. It is transported in a liquid state by pipeline, rail car, or tank truck to retail markets.

ADVANTAGES: Can be used for most gas-fired equipment with only minor modifications.

DISADVANTAGES: Requires an on-site storage tank.

5. SOLAR AS AN ENERGY SOURCE.

The use of solar energy to provide a portion of the home's space or water heating is a good option in many geographic areas. Passive systems use building orientation and construction materials to enhance natural processes to collect, store, and distribute heat. Active systems employ pumps and/or fans. Hybrid systems use small pumps or fans to enhance the performance of a passive system. Photovoltaic (PV) systems convert solar energy directly to DC power which is inverted to AC power for home use. Unfortunately, the market advancement of this technology is suffering from the costly and limited production of the ultra-pure silicon wafers which are the main component of the PV system (Fig. 3).

ADVANTAGES: Minimal operating cost. Environmentally benign.

DISADVANTAGES: Initial cost for design and installation. Optimum location issues and aesthetics.

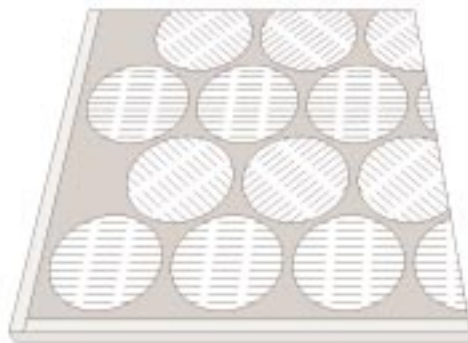

FIGURE 3

PHOTOVOLTAIC PANEL WITH SILICON WAFERS

FURTHER READING

Passive Solar Design Strategies: Guidelines for Home Builders, Passive Solar Industries Council, 1331 H Street NW, Suite 1000, Washington, D.C. 20005; 202-628-7400.

Simplified Design of HVAC Systems, William Bobenhausen, New York: John Wiley & Sons, Inc. 1994.

DISTRIBUTION SYSTEMS

ESSENTIAL KNOWLEDGE

By the end of World War I, the majority of urban homes and many rural homes were centrally heated by a hot-air, hot-water, or steam distribution system. Today there are four basic methods or media for distributing heat in the home: steam, air, water, and electric resistance. All have unique characteristics which may or may not be desirable for the house being rehabilitated.

Steam is one of the oldest types of central heat distribution systems. A boiler produces steam piped through the house to radiators, which provide concentrated heating surfaces in each room. Such systems are either one-pipe or two-pipe. One-pipe systems require a larger pipe because steam rises to the radiators while condensate returns in the same pipe from the radiators to the boiler. If the single pipe is too small, steam will force condensate back up the pipe, causing noise as steam slugs through pockets of water. Two-pipe systems use smaller pipe but twice as much of it because separate steam supply and condensate return lines are installed. Gravity or a condensate pump may be used to return the condensate to the boiler, depending on the height of the condensate piping relative to the boiler. Two-pipe systems installed after World War I include “steam traps” to prevent steam from getting into the return piping.

Air is by far the most common distribution medium for heating and cooling systems. Forced-air heating systems were used in 63% of the homes in the U.S., according to 1993 census data. Original “gravity” air distribution systems relied on natural convection. Heated warm air would rise and distribute itself through the home as cold air fell to be reheated. These systems often resulted in uneven temperatures in the home. As electricity became available to homes, forced-air systems replaced most of the gravity systems. These systems employ forced convection, using an electric fan, to push the hot air through duct work and supply registers throughout the home and pull cold air through the return (Fig. 1). Converting a gravity system to a forced-air system involves more than adding a fan to the system. A new ductwork system should be installed with proper duct sizes and register locations to assure the appropriate distribution of warm air throughout the home.

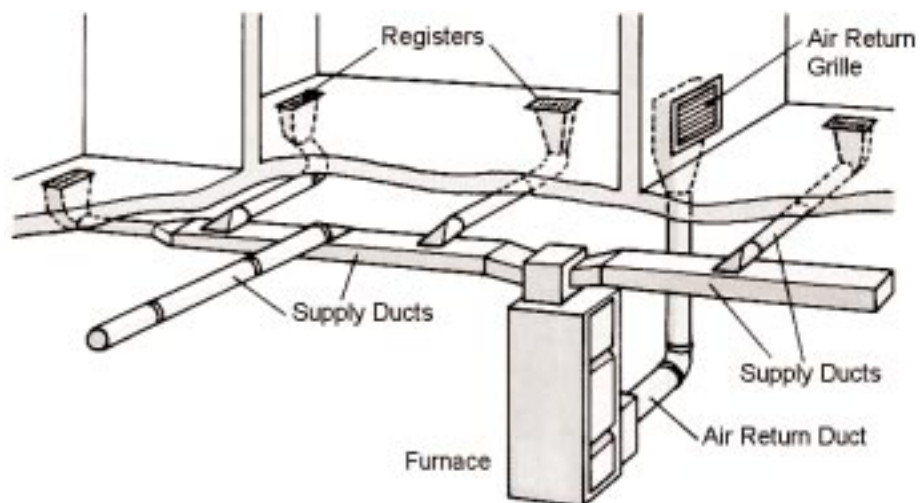

FIGURE 1

TYPICAL FORCED-AIR DISTRIBUTION SYSTEM

Water, or hydronic, systems are efficient because the higher heat capacity of water requires less pumping energy than fan energy in an air system. They are also inherently safer than steam systems because it is nearly impossible to run a hot-water boiler to dangerous pressures. Old hot water systems relied on gravity flow. Hot water expands as it is heated, rises to the radiators, and forces the condensed water through the return piping to the boiler. An expansion tank with an overflow pipe discharges any extra water in the system. Today's systems employ a pump and forced flow (Fig. 2). Hot water moves at a greater speed with better heat transfer efficiency through smaller pipes. In a typical hydronic system, hot water passes through a finned pipe in a baseboard radiator located at the base of the outside wall. Air is warmed and rises by convection to circulate into the room. (They are called radiators, but more heat is delivered via convection than radiation.) True radiant systems with pipes embedded in the floor are also available at an installation cost premium.

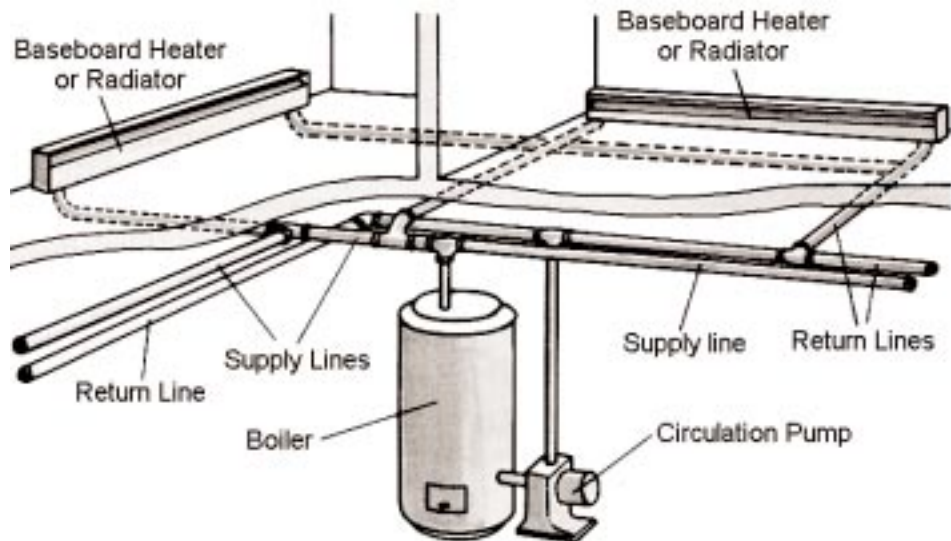

FIGURE 2

TYPICAL HYDRONIC DISTRIBUTION SYSTEM

Electric resistance distribution systems typically use baseboards (Fig. 3), but may include wall units or radiant systems using embedded cable or panels. These systems are sometimes referred to as zonal or direct because the primary source of heating or cooling is within the space. There is no distribution system from a centrally located system. In common electric baseboard systems, the air is heated and relies on convection to distribute heat to the room, similar to hydronic baseboard systems. Electricity can also be used in radiant panel systems which can be surface mounted to existing walls and ceilings. Electric resistance systems are typically inexpensive to install, but generally more expensive to operate because of the high cost of electricity. However, effective use of controls and zoning can reduce operating costs.

Independent of the type of distribution, the existing system in an older home is likely to need major repair or replacement. Corrosion and leaks in duct work and piping can contribute to inefficiency, poor comfort, and poor indoor air quality. Asbestos insulation may also be present on the old duct work or pipes. If so, it should be either removed or encased by a professional contractor. If the asbestos insulation is in good condition, encasing it may be more cost effective than removal. Recommendations regarding the removal and disposal of asbestos are available from the Environmental Protection Agency (EPA) Asbestos Information Hotline: 800-438-2474.

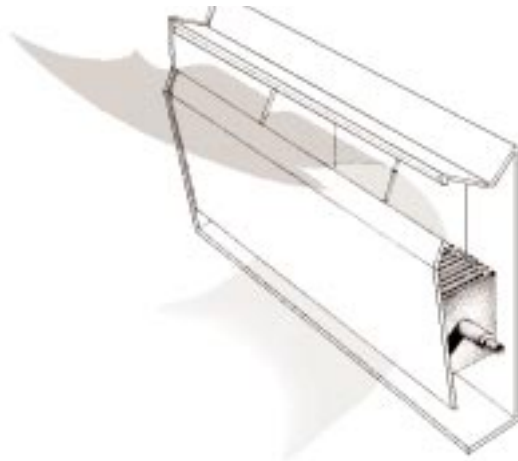

FIGURE 3

ELECTRIC BASEBOARD

TECHNIQUES, MATERIALS, TOOLS

1. REHAB THE EXISTING FORCED-AIR DISTRIBUTION SYSTEM.

Restoring the existing distribution system will likely involve sealing the supply duct work to minimize the loss of conditioned air before it reaches the supply registers. According to a HUD study, leaky duct work can increase heating and cooling costs by as much as 30% and cause air pressure problems that result in drafts and uneven room temperatures. Return duct work should be sealed so that unconditioned air from an attic or crawlspace is not pulled into the system. Instead of sealing tape, mastic should be used because it seals better, lasts longer, and is easier to apply. A relatively new system for sealing ducts, particularly useful in retrofit situations where access can be limited, is aerosolized mastic. Ducts are sealed from the inside by pumping aerosolized mastic into the ducts under pressure. The mastic migrates through the system and seals small leaks without coating the interior of the ducts. Note that this works for small openings only. Once sealed, all supply and return ducts that pass through unconditioned space such as attics, crawlspaces, and basements should be insulated to minimize conduction losses in the winter (and gains in the summer, if used for air conditioning). Old registers and grilles that are no longer (or never were) adjustable should be replaced with new adjustable equipment for better air distribution and comfort.

ADVANTAGES: Improved efficiency, comfort, and safety.

DISADVANTAGES: Rehabilitation of a poorly designed system provides minimal benefit.

2. REHAB THE EXISTING HYDRONIC DISTRIBUTION SYSTEM.

For hot water systems, restoring the existing distribution system will likely involve replacing rusted pipe sections and insulating pipes running through unconditioned spaces. The best type of pipe insulation consists of 3' sections of extruded-foam that is slit so it can be applied over the pipe. Valves that are no longer operable should be replaced, as should old baseboard radiators with bent fins or guards. Replacing radiators is probably more an issue of lifestyle and aesthetics. Finned copper radiators work faster and have a higher heat output than old-style cast-iron radiators, but the cast-iron radiators hold more water and give off heat for a longer time. There are 3-way thermostatic bypass valves, such as those distributed by Enerjee, which can be retrofitted to existing hydronic baseboard units. When the room temperature sensed at the valve is satisfactory, circulating hot water is bypassed around the finned-tube to minimize the heat distributed to the room. This type of valve is intended for use with continuously circulating systems, but could be useful for redistributing the loads on a hydronic system without changing the baseboard units.

For steam systems (Fig. 4), restoring the existing distribution system will likely involve repairing or replacing radiator valves, which serve as an on/off control, and should either be fully open or closed. Worn valve seats can result in gurgling as steam leaks in, but condensate can't flow back. The stem pack-

ing for most radiator inlet valves deteriorates with time; the valves can be repacked with special graphite-impregnated cord. Broken valve handles should be replaced with new handles of insulating plastic. Vents control the rate at which steam enters the radiator (and thus the radiator's output) by regulating the amount of air in and out of the radiator. If the radiator never heats up (never hisses) or steam comes out of the vent (continuously hisses), the vent needs to be replaced. Replacement of vents with the proper speed can also help with unbalanced heat distribution in the home. Vents come in four speeds (very slow, slow, fast, and very fast) or variable. For rooms that tend to overheat, use a slower vent and vice versa. Vacuum vents allow air to escape, but not reenter as the radiator cools. A vacuum is created within the radiator as the steam condenses and hot steam is drawn into the radiator rather than cold air. This can result in a more steady output of heat. Special "packless" airtight control valves need to be installed in conjunction with the vacuum vents. Radiators should be sloped slightly towards the steam valve. If they are not, condensate will likely pool at the far end of the radiator and steam bubbling through will "gurgle." A shim should be placed under the radiator feet farthest from the valve to slope the radiator slightly towards the valve.

ADVANTAGES: Low cost and least disruptive.

DISADVANTAGES: Hydronic systems are only suitable for heating.

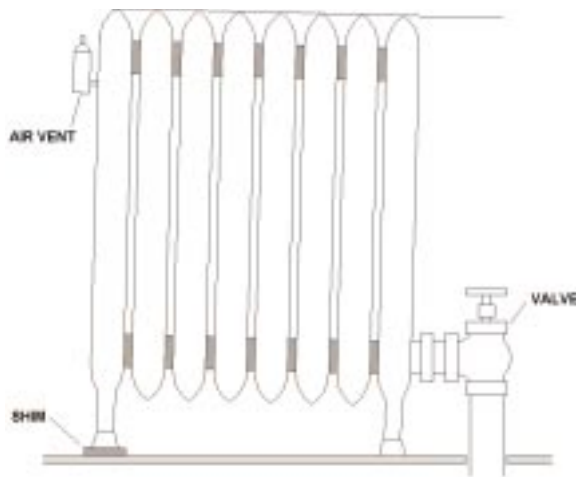

FIGURE 4

STEAM RADIATOR

3. REHAB THE EXISTING ELECTRIC RESISTANCE SYSTEM.

While electric resistance systems are relatively simple with few parts, there may still be the need for rehabilitation. In addition to cleaning, damaged fins or fin guards should be repaired or replaced because they affect the performance of a baseboard.

ADVANTAGES: Improved performance.

DISADVANTAGES: Replacement of the entire unit may be simpler than repairing or replacing components.

4. INSTALL A NEW CONVENTIONAL FORCED-AIR DISTRIBUTION SYSTEM.

Conventional forced-air distribution systems are by far the most common type of heating system. However, they are notorious for being the cause of inefficiency and discomfort. Poorly designed and installed ductwork can have high levels of air leakage and poor temperature control. Systems are often designed with poorly insulated ductwork running through unconditioned space. A design which keeps ductwork within the conditioned space avoids many of these problems. Duct losses are reduced because conditioned air is leaking into the conditioned space and conduction losses are lower because temperature differences between the supply and surrounding air are less. The location of supply outlets depends upon whether the emphasis is on heating or cooling. For heating-dominated systems, standard practice has been to install supply registers along the outside walls under windows to counter cold drafts coming from windows. However, in a tightly constructed home with insulating windows, interior wall registers can be used to save on duct material. For

cooling-dominated systems, ceiling supply diffusers are most appropriate. Ducts are usually made of square and/or round sheet metal, but insulated duct board and flex duct are also widely used. Fiberglass duct board is quieter than sheet metal ducts because such ducts attenuate the blower noise that can propagate through the duct system. Care must be taken to avoid problems with condensation, which contributes to mold growth, if the system is used for air conditioning. Owens Corning has introduced EnDuraCoat—a duct board system with an antimicrobial acrylic interior coating to resist the growth of fungi and bacteria.

ADVANTAGES: Distribution system widely used and accepted. Can readily include air conditioning, humidification, or air purification. Fast responding.

DISADVANTAGES: Significant space requirements of ductwork can make installation in an existing structure difficult and costly if the previous distribution system was not air. Duct system leakage can cause inefficiency. Forced-air systems can be noisy.

5. INSTALL A MINI-DUCT HVAC SYSTEM.

There are at least two systems on the market, Unico and SpacePak, that feature small-diameter, flexible ductwork that can pass through studs and joists and snake through narrow openings and around corners (Fig. 5). The typical system delivers less air at higher velocities than conventional forced-air systems; to achieve the same heating or cooling capability, the air is delivered at higher temperatures when heating and lower temperatures when cooling. Air is discharged through plastic collars with 2" diameter holes in the ceiling, floor, or wall. Since air is supplied at more extreme temperatures and higher velocities, these outlets must be strategically placed to avoid blowing directly on occupants. Special sound attenuating tubing is used at the end of each supply run to minimize the noise caused by high air velocities.

ADVANTAGES: Ducts can be installed in tight areas. Lower supply air temperatures may provide better humidity control in the summer.

DISADVANTAGES: System is unfamiliar to building professionals. Lower installation cost might be offset by higher equipment cost.

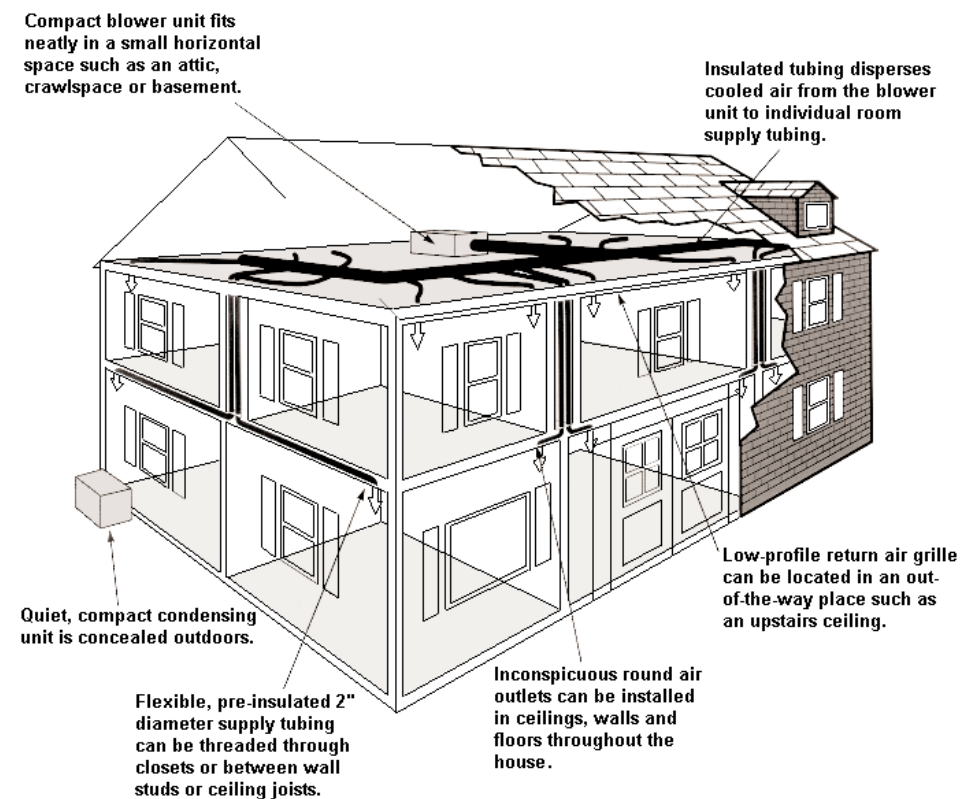

FIGURE 5

MINI-DUCT DISTRIBUTION SYSTEM

6. INSTALL A NEW HYDRONIC DISTRIBUTION SYSTEM.

There are alternative types of hydronic systems to consider. Systems involving traditional baseboards can be single-pipe or two-pipe, and radiant systems are also an option. All hydronic systems require an expansion tank to compensate for the increase in water volume when it is heated (i.e., the volume of 50°F water increases almost 4% when it is heated to 200°F). Single-pipe hydronic systems are most commonly used in residences. They employ a single pipe with hot water flowing in a series loop from radiator to radiator. The drawback to this arrangement is that the temperature of the water decreases as it moves through each radiator. Thus, larger radiators are needed for those locations downstream in the loop. A common solution to this is multiple loops or zones. Each zone has its own temperature control with circulation provided by a small pump or zone valve in each loop (Fig. 6). Two-pipe hydronic systems use a pipe for supplying hot water to the radiators and a second pipe for returning the water from the radiators to the boiler. There are also direct- and reverse-return arrangements (Fig. 7). The direct-return system can be difficult to balance because the pressure drop through the nearest-radiator piping can be significantly less than for the farthest radiator. Reverse-return systems take care of the balancing problem, but require the expense of additional piping. Orifice plates at radiator inlets or balancing valves at radiator outlets can also be used to balance the pressure drops in a direct-return system.

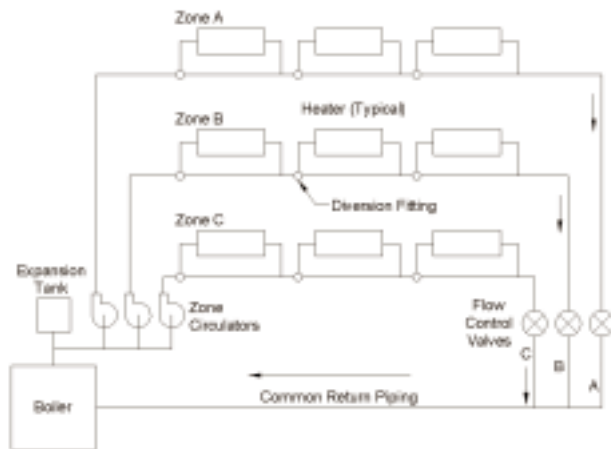

FIGURE 6

MULTI-ZONE SINGLE-PIPE HYDRONIC DISTRIBUTION SYSTEM

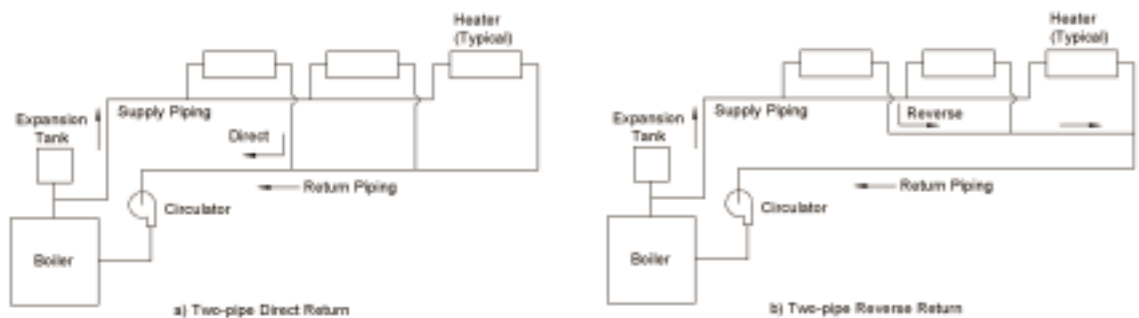

FIGURE 7

TWO-PIPE HYDRONIC DISTRIBUTION SYSTEMS

Radiant systems run hot water through plastic pipe or tubing typically embedded in floor slabs or under framed floors (Fig. 8). Systems involving panels that look like baseboard molding or panels that can mount in the wall or ceiling are also available. These systems warm the surrounding objects rather than the air and can generally provide better comfort than baseboard systems. The introduction of cross-linked polyethylene (PEX) tubing to the U.S. market in the 1980s revolutionized the installation of hydronic floor heating with fast installation and longer service life.

There are also radiant cooling systems which involve running cool water through the same pipe or tubing or panels as used for heating. These systems must be designed carefully to insure that the temperature of the radiant surface (floor, ceiling, or wall panel) remains above the dewpoint of the room air. Otherwise, harmful and potentially dangerous, in the case of a slippery floor, condensation can occur. For this reason, radiant cooling systems typically supplement another type of cooling system.

ADVANTAGES: Small piping or tubing is more adaptable to an existing building structure than ductwork. Hydronic systems are clean, quiet, have fewer heat losses, and can be easily zoned.

DISADVANTAGES: Hydronic systems are only used for heating. Radiant cooling systems are not commonly used and are therefore more difficult to design and usually more costly than other alternatives.



FIGURE 8

HYDRONIC RADIANT FLOOR HEATING SYSTEM

7. INSTALL A ZONAL SYSTEM.

A zonal system utilizes individual in-space heaters in each of the rooms to be heated. Essentially, there is no distribution system with its inherent losses and inefficiencies. Significant savings can be achieved through the use of setback controls and zoning; providing heat when and where it is needed. These heaters can be electric or gas and may employ natural convection, fan-forced convection, and/or radiation to transmit the heat to the space. Some units also include a thermal storage medium to improve comfort.

Gas space heaters are available from several manufacturers in a range of capacities. The units employ sealed-combustion so there is no potential of mixing combustion gases with the internal air via spillage or backdrafting. Direct-vent units operate with efficiencies of 60 to 75%. They mount on an external wall and vent the combustion gases through the wall (Fig. 9). Power-vented units with efficiencies above 80% can duct the exhaust gases so they have more location flexibility.

Electric heaters are less expensive than gas-fired heaters but electricity is typically the more expensive fuel. Electric baseboard heaters are the most common zonal heater in residential applications. Other electric units include wall, kickspace, floor and ceiling heaters. Baseboard units typically rely on natural convection while the other types include a fan to augment the convection process. Some units are

available with two stages to better match the output to the load. Others include an electric immersion element and a liquid solution hermetically sealed in copper tubing. The thermal capacitance of the liquid serves to modulate the output of the unit.

Radiant systems that use ceiling, wall, or floor panels with electric wiring embedded are also a type of zonal system. These units can be faster responding than hydronic radiant systems.

ADVANTAGES: Zonal systems are inexpensive to install, offer flexibility, and provide zone-control capability.

DISADVANTAGES: The types of zonal systems discussed only provide heating.

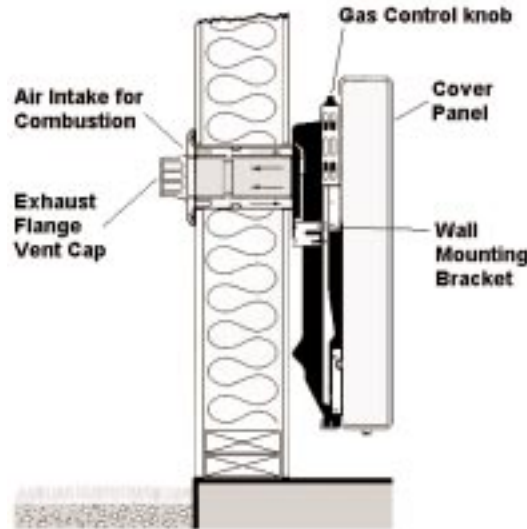

FIGURE 9

DIRECT-VENT GAS SPACE HEATER

FURTHER READING

Modern Hydronic Heating for Residential and Light Commercial Buildings, John Siegenthaler, Delmar Publishers, 1995.

Renovating Old Houses, George Nash, Newton, CT: The Taunton Press, 1992.

Simplified Design of HVAC Systems, William Bobenhausen, New York: John Wiley & Sons, Inc., 1994.

The Old-House Journal Guide to Restoration. Patricia Poore, editor; New York: Penguin Books, 1992.

PRODUCT INFORMATION

Burnham Radiant Heating Co., P.O. Box 3079, Lancaster, PA 17604; 717-397-4701; www.burnham.com.

Enerjee, 24 S. Lafayette Ave., Morrisville, PA 19067; 215-295-0557; www.enerjee.com.

Empire Comfort Systems, 918 Freeburg Avenue, Belleville, IL 62222; 800-851-3153; www.empirecomfort.com.

Owens Corning World Headquarters, One Owens Corning Parkway, Toledo, OH 43659; 419-248-7817; www.owenscorning.com.

Radiant Technology, 11A Farber Drive, Bellport, NY 11713; 800-784-0234; www.radiant-tech.com.

SpacePak, Mestek, Inc., Westfield, MA; 413-564-5530; www.spacepak.com.

SSHC, Inc., 146 Elm Street, Old Saybrook, CT 06475; 800-544-5182; www.sshcinc.com.

Unico, Inc., 4160 Meramec Street, St. Louis, MO 63116; 800-527-0896; www.unicosystem.com.

ESSENTIAL KNOWLEDGE

There are two basic types of central heating plants: furnaces (used with air distribution systems) and boilers (used with either hydronic or steam systems). Another less common alternative is to use a domestic hot water heater to supply hot water to a hydronic coil in an air handling unit or for a radiant system. These systems are often referred to as combination systems and are gaining in popularity.

Warm-air furnaces (Fig. 1) are the most common residential heating system in the U.S. According to 1993 census data, furnaces are used in 37% of electrically-heated homes and 69% of gas-heated homes. If a gas- or oil-fired furnace is presently installed in the house to be rehabilitated, it is probably much less efficient than today's furnaces. The efficiency of most gas- or oil-fired furnaces installed 20 years ago is between 50% and 65%. Standards that went into effect in 1994 require that furnaces sold today be at least 78% efficient. This standard essentially eliminated the use of standing pilots on gas furnaces, and electronic ignition devices and vent dampers became standard. Gas-fired models with efficiencies over 90% and oil-fired models with efficiencies as high as 87% are available today.

Furnaces are available in upflow, downflow, and horizontal configurations. Upflow systems are the most common, with blowers drawing air into the bottom and supplying heated air out the top to the duct system. Downflow systems draw air in at the top and supply heated air out the bottom for floor duct systems. Horizontal systems draw air in one side and supply heated air out the other side. They are used in attics, crawl spaces, below floors, or suspended from ceilings.

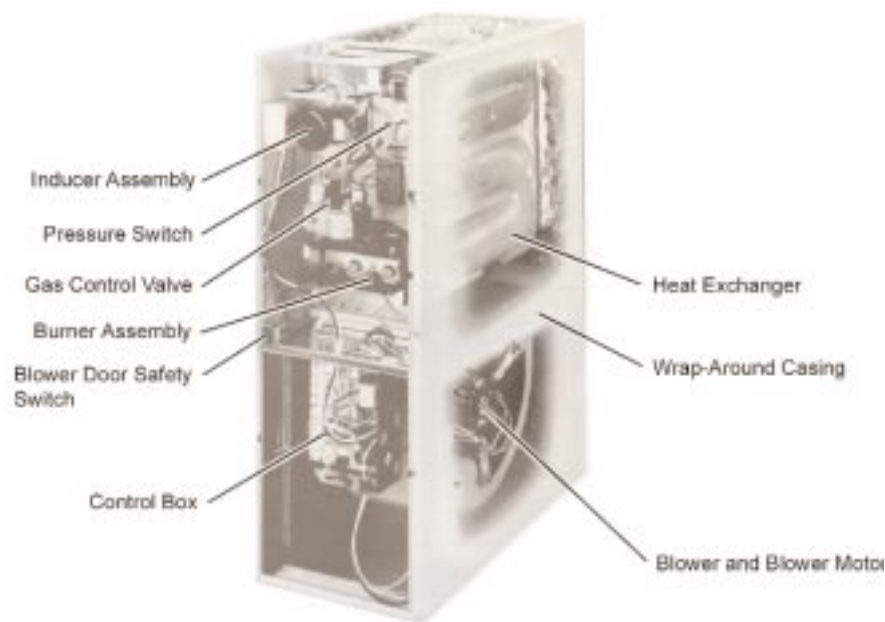

FIGURE 1

GAS-FIRED FURNACE

According to 1993 census data, boilers are used for heating in 15% of homes across the U.S. and approximately 45% of those in the Northeast (Fig. 2). Government standards require that today's residential combustion boilers have efficiencies of at least 80%. The Quantum Leap boiler by Dunkirk Radiator has a 95% efficiency. While boiler efficiencies are typically lower than furnace efficiencies, total system efficiency, including distribution system losses, can be higher because duct losses are typically higher than pipe losses.

Electric furnaces and boilers operate with a 100% fuel conversion efficiency. However, distribution system losses often make them less efficient as a system than electric baseboard or other zonal systems. If an electric furnace is presently installed in the home, the integrity of the duct work system should be examined and improved as a minimum (see Section 3). If the electric furnace or boiler is situated in a cold climate, serious consideration should be given to converting it to a gas-fired system to reduce operating costs.

This section will focus on fuel-burning, or combustion, systems. In combustion systems, combustion occurs within a chamber and air circulates over the outside surfaces of a heat exchanger. The circulation air does not come in contact with the fuel or the products of combustion, which are vented to the outside. Traditional combustion systems are natural draft (or atmospheric vent) with a draft hood to carry the combustion gases through the vent to the outdoors. The draft hood has a relief air opening to assure that the exit of the combustion heat exchanger is at atmospheric pressure. Fan-assisted or powered-combustion systems use a small blower to force (forced-draft, power burner) or induce (induced-draft, mechanical draft, power vent) the flue products through the system. Fan-assisted systems do not require a draft hood, resulting in reduced off-cycle losses and improved efficiency.

Backdrafting of combustion appliances occurs when the surrounding area is depressurized and the appliance relies on natural draft to carry the combustion gases through the vent to the outdoors. Backdrafting can be dangerous when deadly combustion gases are drawn into the living space. Depressurization can occur when other devices such as exhaust fans, water heaters, clothes dryers, and fireplaces are drawing air from the space and exhausting it to the outside. The best solution to this problem is the installation of a direct-vent combustion system that uses outside air for combustion and does not have a draft hood. This is referred to as a sealed combustion system because the combustion air is isolated from the indoor air.

The following are techniques for improving the safety, efficiency and/or reducing the operating costs of the existing combustion furnace or boiler system. For safety reasons, all modifications should be performed by a qualified mechanic.

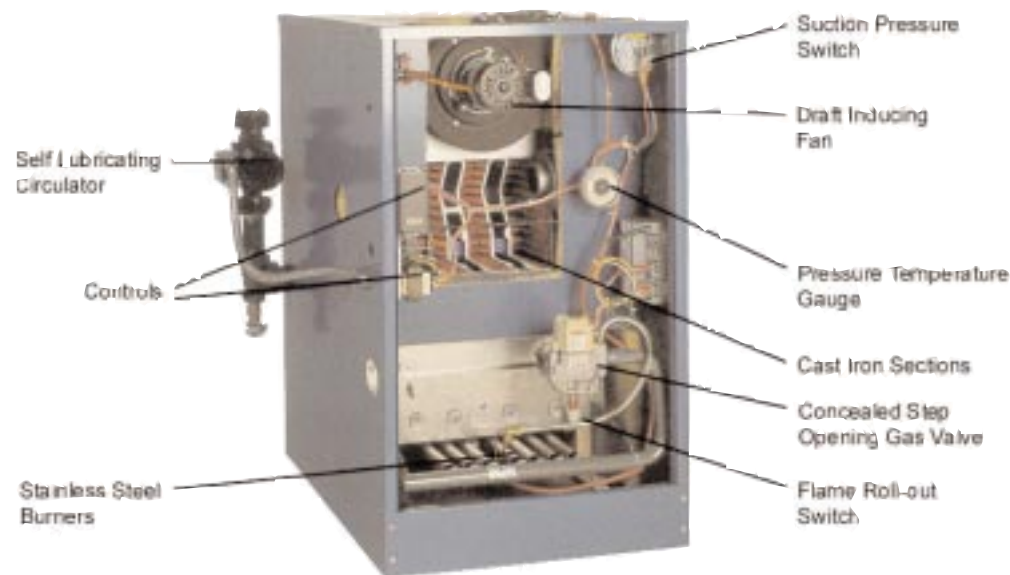

FIGURE 2

GAS-FIRED BOILER

1. FOR OIL-FIRED SYSTEMS, INSTALL A FLAME-RETENTION BURNER.

Flame-retention burners have smaller air intakes and a more concentrated flame that enables them to burn hotter and more efficiently.

ADVANTAGES: Improved combustion efficiency.

DISADVANTAGES: None.

2. INSTALL A VENT DAMPER.

A vent damper is a flapper installed in the flue of a draft hood-equipped natural draft furnace or boiler. (Fan-assisted natural draft systems do not have draft hoods.) When the burners are ignited, the damper is open to allow combustion gases to exhaust up the flue to outdoors. The damper closes when the burners are shut off to reduce exfiltration of heated air from the house and to prevent residual heat from the heat exchanger from escaping up the flue. The NAECA standards passed in 1987 made vent dampers a standard feature of today's natural-draft furnaces.

ADVANTAGES: Improved efficiency if the furnace is located in the conditioned space and is using indoor air for combustion.

DISADVANTAGES: Of less value if the combustion air is drawn from outside or unconditioned space.

3. REPLACE THE STANDING PILOT WITH AN ELECTRONIC SPARK IGNITOR.

Old furnaces and boilers employ a standing pilot that consumes a small amount of gas continuously. The NAECA standards passed in 1987 essentially eliminated this energy-wasting practice. Electronic ignitions use an electric spark or a hot surface as an ignition source for the gas mixture when heating is needed.

ADVANTAGES: Improved efficiency.

DISADVANTAGES: Cost of new ignition system.

4. FOR OIL-FIRED FURNACES, DOWNSIZE THE BURNER NOZZLE.

The firing rate of an oil-fired furnace is controlled by the pump pressure and the orifice size of the burner injection nozzle. The nozzles are rated in gallons per hour. If the home's heating loads have been reduced or the system was over-sized initially, the nozzle size may be reduced to decrease the capacity of the furnace.

ADVANTAGES: Improved comfort through less system cycling.

DISADVANTAGES: Smaller nozzles become clogged more easily by sediment. Fuel line filters may need to be changed more frequently.

5. INSTALL AN ADVANCED, HIGH-EFFICIENCY GAS FURNACE.

High-efficiency gas furnaces can offer a significant improvement in efficiency. Efficiency ratings between 84% and 89% are not common because acidic corrosive condensate forms at these efficiencies and the modest improvement in efficiency is not worth the added material cost needed to withstand the condensate. Thus, high efficiency means jumping from efficiencies in the low 80s to the low 90s. There are several alternatives available for those who want to install an advanced and efficient furnace system, including pulse and condensing combustion technologies.

Nearly every major furnace manufacturer includes a condensing furnace in their product line. Condensing furnaces are designed to condense the water vapor from the exhaust gases and capture the heat of condensation. This is done by lowering the temperature of the combustion gases with a second heat exchanger in the furnace (Fig.3). Condensing furnaces are expensive because they require corrosion-resistant materials, but they can have efficiencies as high as 97%.

Pulse combustion is a technology patented by Lennox that involves self-perpetuating "pulses" at a rate of approximately 60 times per second. Air and fuel are mixed in the combustion chamber and ignited by a spark from a spark plug in a manner similar to an automobile internal combustion engine. The increase in pressure upon ignition closes the gas/air inlet valve. The combustion products are forced

through an exhaust pipe and the gas/air inlet valve reopens with the reduction in pressure. The next combustion pulse is ignited by the heat remaining from the previous pulse. Pulse combustion furnaces have efficiencies of 91% to 97%.

A few manufacturers provide furnaces with two-speed or even variable speed motors. These systems can improve comfort and run quieter when used with zoning systems, with an air-conditioning system that requires a higher air flow, or when it is desirable to run the fan continuously for ventilation air supply. The Carrier Weathermaker 8000 and Trane XV-80 are two such products.

ADVANTAGES: Lower operating costs. Higher efficiency systems have lower temperature exhaust gases so PVC piping can be used for venting, a significant advantage if a chimney is not currently in place. The multi-speed systems provide better comfort because output follows load more closely. The low-speed setting can provide dehumidification capability with an AC unit.

DISADVANTAGES: Higher initial cost and the existing flue may need to be downsized. All fan-assisted furnaces consume more electricity than old furnaces that did not use a fan in the combustion air stream. Local code may require a neutralizer cartridge for condensate disposal. If condensate cannot be drained by gravity, a condensate pump is necessary.

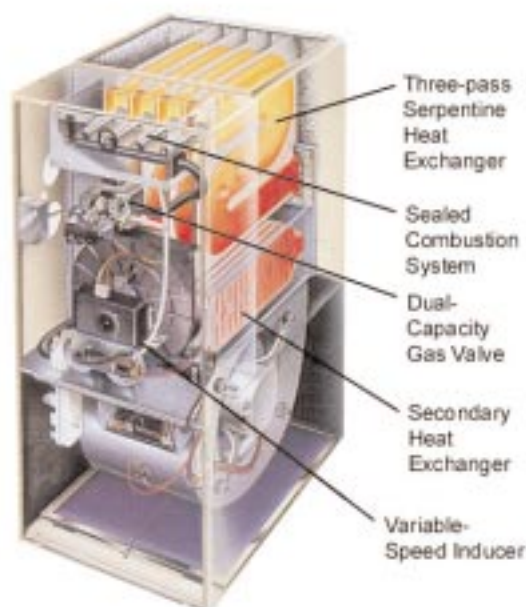

FIGURE 3

CONDENSING FURNACE

6. INSTALL A COMBINATION SYSTEM.

Combination systems use one combustion device to provide space and water heating. These systems eliminate the gas furnace and its flue by running a hot water coil from the domestic hot water heater to the air-handling unit or a hydronic radiant system (Fig. 4). The Gas Research Institute estimates that nearly a million of these systems have been installed in the U.S.

Typically, potable water is used in the air-handler heating coil. For hydronic radiant systems, a separate heat exchanger in the water heater is used to circulate non-potable water through the radiant system piping. This is a code requirement in most areas.

Water heaters specifically designed for these systems are available. They have an extra set of taps for supply and return of the space heating water and higher recovery rates and direct-venting as options.

ADVANTAGES: Eliminates the furnace and its venting requirements.

DISADVANTAGES: Dealer confusion over sizing and designing of systems.

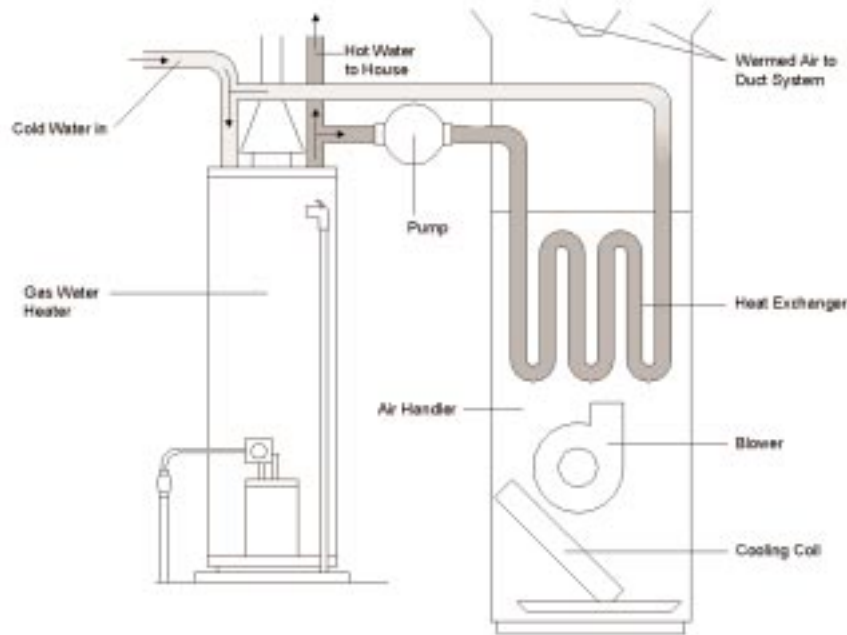

FIGURE 4 COMBINATION HEATING SYSTEM

7. INSTALL AN ADVANCED HIGH-EFFICIENCY BOILER.

Condensing boilers are less common than furnaces because they typically are not compatible with the high return-water temperatures, such as the 160°F of a hydronic baseboard system. They are appropriate for the lower temperatures of radiant systems. However, Dunkirk Radiator produces the Quantum Leap boiler with an efficiency of 95%. This unit, which uses an aluminum heat exchanger, is a condensing boiler even at high return-water temperatures. Condensation at high return-water temperatures is accomplished by heating and saturating the incoming combustion air to raise its dewpoint. This is done with the condensate in an evaporative tower (Fig. 5).

ADVANTAGES: Lower operating costs. Higher efficiency systems have lower temperature exhaust gases so PVC piping can be used for venting. Improved safety devices and controls over an old boiler system.
DISADVANTAGES: Higher initial cost.

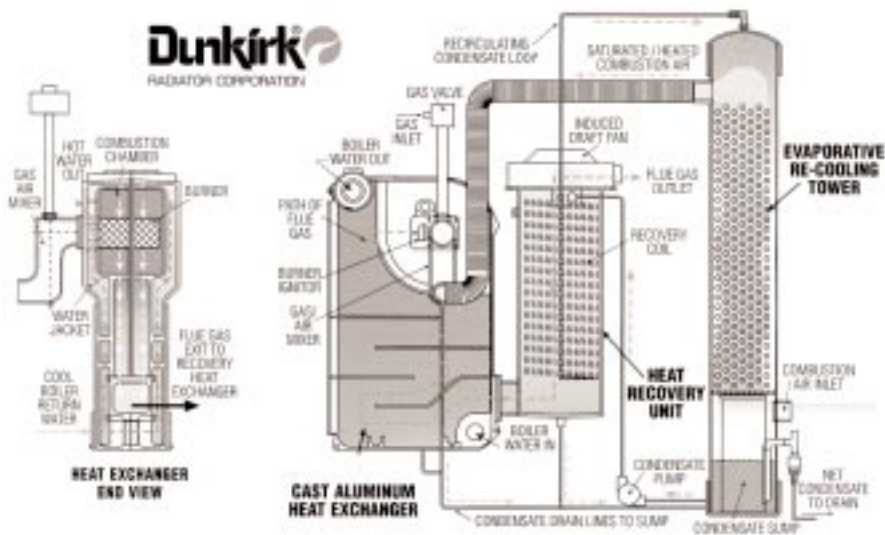

FIGURE 5 QUANTUM LEAP CONDENSING BOILER

FURTHER READING

A Consumer's Guide to Home Improvement, Renovation & Repair, The Enterprise Foundation, Robert M. Santucci, Brooke C. Stoddard, and Peter Werwath, John Wiley & Sons, Inc., 1995.

Consumers' Directory of Certified Efficiency Ratings for Residential Heating and Water Heating Equipment, Gas Appliance Manufacturers' Association, available from ETL Testing Laboratories, Inc.; 607-753-6711.

1996 ASHRAE Systems and Equipment Handbook, ASHRAE, 1791 Tullie Circle, NE, Atlanta, GA 30329; 404-636-8400.

PRODUCT INFORMATION

Apollo HydroHeat & Cooling, A Division of State Industries, 500 Bypass Road, Ashland City, TN 37015; 615-792-4371; www.stateind.com.

Burnham Corporation, P.O. Box 3079, Lancaster, PA 17604; 717-397-4701; www.burnham.com.

Carrier North American Operations, P.O. Box 4808, Carrier Parkway, Syracuse, NY 13221; 315-432-6000; www.carrier.com.

Dunkirk Radiator Corporation, 85 Middle Road, Dunkirk, NY 14048; 716-366-5500; www.dunkirk.com.

Lennox Industries, 2100 Lake Park Boulevard, Richardson, TX 75080; 214-497-5000; www.davelennox.com.

Trane Company, 3600 Pammel Creek Road, LaCrosse, WI 54601; 608-787-3111; www.trane.com.

York International Corporation, 631 South Richland Avenue, York, PA 17403; 717-771-7890; www.york.com.

ESSENTIAL KNOWLEDGE

Many old homes relied on passive cooling — the opening of windows and doors, and the provision of shading devices — during the summer months. Homes were designed with windows on opposite walls to encourage cross ventilation and large shade trees reduced solar heat gains. This approach is still viable in many areas today and improved thermal performance (insulating value) windows are available that allow for larger window areas to let in more air in the summer without the heat loss penalty in the winter. However, increased outdoor noise levels, pollution, and security issues make relying on open windows a less attractive option in some areas today.

An air-conditioning system of some kind may already be installed in the home. It may be a window air conditioner or through-the-wall unit for cooling one or two rooms, or a central split-system air conditioner or heat pump. In any event, the performance of these systems in terms of providing adequate comfort without excessive energy use should be investigated. The age of the equipment alone will provide some indication. If the existing system is more than ten years old, replacement should be considered because it is much less efficient than today's systems and nearing the end of its useful life.

The refrigerant commonly used in today's residential air conditioners is R-22. Due to the suspicion that R-22 depletes the ozone layer, manufacturers will be prohibited from producing units with R-22 in 2010. The leading replacements for R-22 are R-134A and R-410A and new products are now available with these non-ozone-depleting refrigerants. Carrier's brand name for the R-410A refrigerant is Puron.

The performance measure for electric air conditioners with capacities less than 65,000 Btuh is the Seasonal Energy Efficiency Ratio (SEER). This is a rating of cooling performance based upon representative residential loads. It is reported in units of Btu of cooling per watt-hour of electric energy consumption including the unit's compressor, fans, and controls. The higher the SEER the more efficient the system. However, the highest SEER unit may not provide the most comfort. In humid climates, some of the highest SEER units exhibit poor dehumidification capability because they operate at higher evaporator temperatures to attain the higher efficiency. A SEER of at least 10 is required by NAECA for conventional central split-system air-cooled systems.

Cooling system options vary widely, depending upon the level of control and comfort desired by the homeowner. Fans can increase circulation and reduce cooling loads, but their cooling capability is directly limited by the outdoor conditions so they may be unsatisfactory in hot climates. Radiant barriers can possibly reduce cooling loads in very hot climates. Evaporative coolers can be a relatively inexpensive and effective method of cooling in dry climates such as the Southwest. Electric air conditioning is the answer for those who want to maintain a comfortable indoor temperature and humidity even under the most severe outdoor conditions. Over 75% of new homes in the U.S. are equipped with some form of central air conditioning; more specifically, 50% of the homes in the Northeast, 75% in the Midwest, 95% in the South, and approximately 60% in the West. Electric air conditioning filters and removes moisture from the air as well as reducing its temperature. It can be a good investment because, in most parts of the country, the payback is significant when the house is sold.

TECHNIQUES, MATERIALS, TOOLS**1. INSTALL A CIRCULATION FAN.**

Air movement can make you feel comfortable even when dry-bulb temperatures are elevated. A circulation fan (ceiling or portable) (Fig. 1) that creates an airspeed of 150-200 feet per minute can compensate for a 4°F increase in temperature.

ADVANTAGES: The same ceiling circulation fan can also be beneficial in the heating season by redistributing warm air that collects along the ceiling.

DISADVANTAGES: Can be noisy.



FIGURE 1

CEILING CIRCULATION FAN

2. INSTALL A POWER ATTIC OR ROOFTOP VENTILATOR.

These units are used to assist the natural flow of air through the attic space (Fig. 2). Without good ventilation, attic temperatures can exceed 130°F on warm, sunny days. Increasing the attic ventilation results in a cooler attic space, reducing the cooling load on the space below. To estimate the required CFM-rating of an attic ventilator, multiply the attic floor area by a factor of 0.75 and increase the value by 15% if the roof is dark and will absorb heat. The exhausted air is replaced by outside air entering through eave vents.

ADVANTAGES: Inexpensive and easy to install.

DISADVANTAGES: Does not directly cool the living space. If attic vent area is insufficient, the fan can draw air through the ceiling of the conditioned space and potentially depressurize the space.



FIGURE 2

POWERED ATTIC VENTILATOR

3. INSTALL A WHOLE-HOUSE VENTILATOR OR FAN.

Whole-house ventilators are typically installed in the attic floor over a hallway or stairway. They pull hot air from the living space and exhaust it into the attic where it exits through the attic vents. Fresh cooler air is drawn in through open windows. Specific areas of the home can be ventilated by selectively opening and closing doors and windows. The HV1000 unit by Tamarack Technologies (Fig. 3) uses efficient fan motors to minimize energy use and noise and has an automatic door assembly that provides an airtight seal with an insulating value of R-22. It uses two side-by-side fans rather than one large fan so that the unit can easily fit between 16" or 24" on center joists with no joist cutting.

ADVANTAGES: Can eliminate the need for mechanical air conditioning in moderate climates.

DISADVANTAGES: Noisy. Limited cooling capability in warm or humid climates. Can depressurize the home if windows are not open. Increased heat loss during the winter if the system is not sealed and insulated.

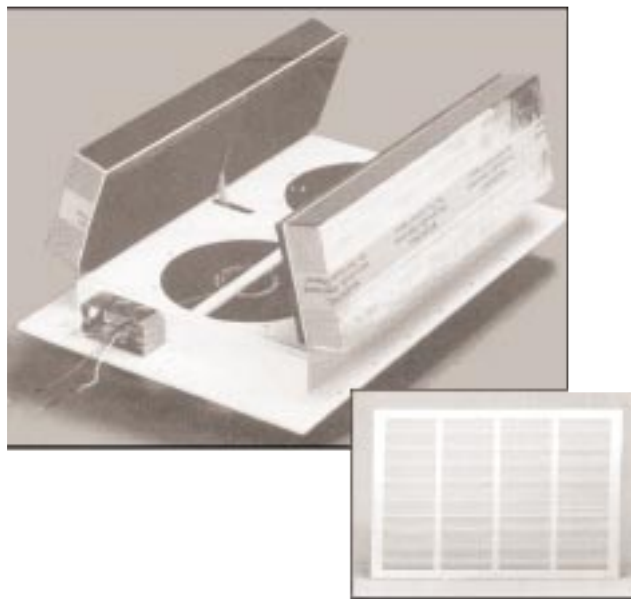

FIGURE 3

HV1000 WHOLE-HOUSE VENTILATOR

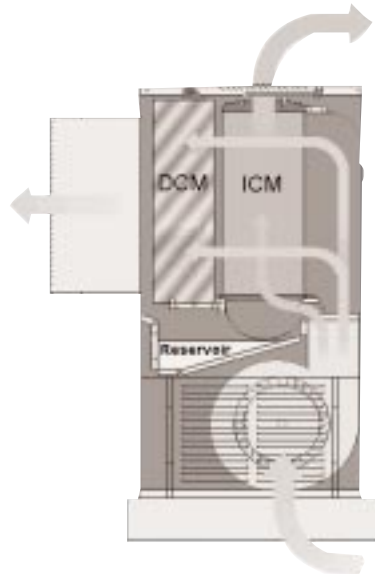

FIGURE 4

TWO-STAGE EVAPORATIVE COOLER

4. INSTALL A RADIANT BARRIER.

In hot climates, where attics can become very hot and air conditioning ducts are often in the attic, a radiant barrier may be beneficial. It can reduce the cooling load on the home and reduce the increase in supply air temperature as conditioned air travels through the supply ducts in the attic before reaching the rooms to be conditioned. Radiant barriers are made of materials that are good at reflecting heat. They reflect the radiant heat emanating from a hot roof, and come in a variety of forms, including foil, paint coatings, and chips.

ADVANTAGES: Fairly simple to install. Can reduce the size of the air conditioner needed.

DISADVANTAGES: Can be relatively expensive. Dust can seriously degrade the performance by dulling the reflective surface.

5. INSTALL AN EVAPORATIVE COOLER.

In dry climates such as the Southwest, an evaporative cooler or “swamp” cooler may provide sufficient cooling. This system cools an airstream by evaporating water into it; the airstream’s relative humidity increases while the dry-bulb temperature decreases. A 95°F, 15% RH airstream can be conditioned to 75°F, 50% RH. The simplest direct systems are centrally located and use a pump to supply water to a saturated pad over which the supply air is blown. Indirect systems use a heat exchanger between the airstream that is cooled by evaporating water and the supply airstream. The moisture level of the supply air stream is not affected as it is cooled. Cool Tech Industries manufactures a two-stage unit that employs an indirect first stage coupled to a direct second stage (Fig.4). Moisture is added to the supply airstream, but not as much as with a direct evaporative cooler.

ADVANTAGES: Lower installation and operating costs than electric air conditioning. No ozone-depleting refrigerant involved. Provide high levels of ventilation because they typically condition and supply 100% outside air.

DISADVANTAGES: Bacterial contamination can result if not properly maintained. Only appropriate for dry, hot climates.

6. INSTALL AN ELECTRIC AIR CONDITIONER

(see Section 6 on Heat Pumps as well).

Electric air conditioners that employ the vapor compression refrigeration cycle are available in a variety of sizes and configurations, ranging from small window units to large central systems. The most common form of central air conditioning is a split-system with a warm air furnace (Fig.5). The same ductwork is used for distributing conditioned air during the heating and cooling seasons. Supply air is cooled and dehumidified as it passes over an A-shaped evaporator coil. The liquid refrigerant evaporates inside the coil as it absorbs heat from the air. The refrigerant gas then travels through refrigerant piping to the outdoor unit where it is pressurized in an electrically-driven compressor, raising its temperature and pressure, and returned to a liquid state in the condenser as it releases, or dumps, the heat to the outdoors as a fan draws outdoor air in over the condenser coil. The use of two-speed indoor fans can be advantageous in this type of system because the cooling load can often require higher airflows than the heating load. The lower speed can be used for the heating season and for improved dehumidification performance during the cooling season.

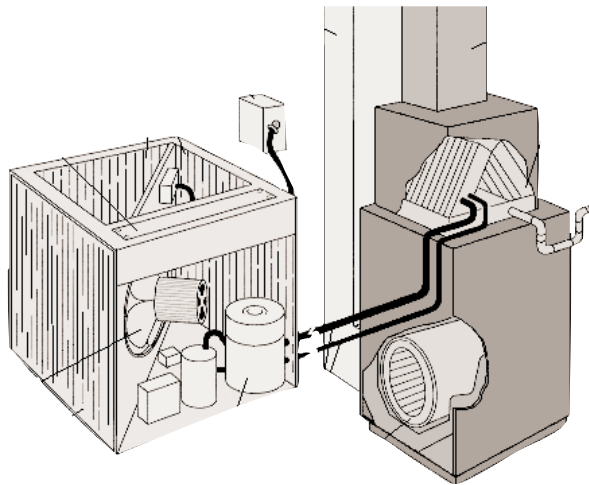

FIGURE 5

SPLIT-SYSTEM AIR CONDITIONER

Another electric air conditioning system configuration is the packaged terminal air conditioner (PTAC) (Fig. 6). These units are similar to window air conditioners in that they are a single package, but they also provide heat and are designed to be installed through an outside wall. A common application is motel rooms. Their cooling capacities are typically larger than window units and smaller than central systems. Most of the units are equipped with electric heating and can be installed without the need for an HVAC contractor because there is no ductwork or refrigerant piping involved in the installation. Noise can be a problem and the wall penetrations can be a source of uncomfortable air leakage in the winter. **ADVANTAGES:** Removes latent heat (moisture) in addition to sensible heat in more humid climates. **DISADVANTAGES:** Compressor and condenser fan can be noisy.

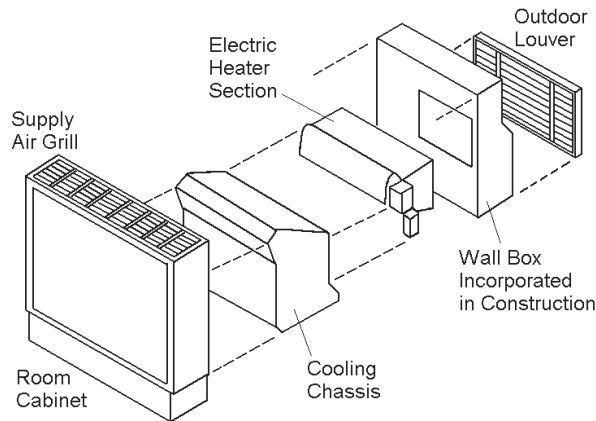

FIGURE 6

PACKAGED TERMINAL AIR CONDITIONER

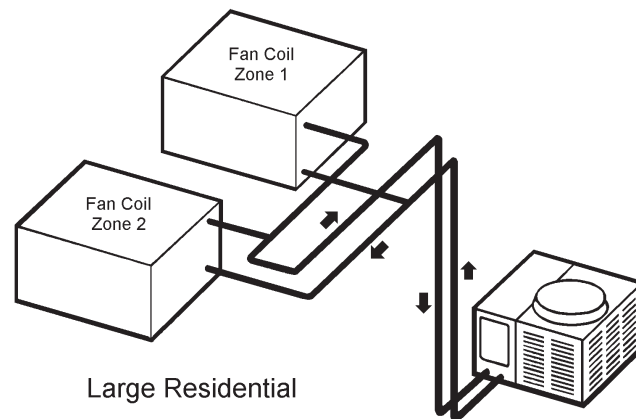

FIGURE 7

GAS-FIRED CHILLER SYSTEM

7. INSTALL A GAS-FIRED CHILLER.

For the situation where central air conditioning is desired and electricity is very expensive or the cost of additional electrical service is excessive, there are gas-fired alternatives. For some 30 years, Robur Corporation has manufactured small tonnage absorption products. The three- and five-ton Serval systems are air-cooled absorption chillers that utilize ammonia. The system is self-contained in an outdoor unit and chilled water piping is run to an indoor air handler unit (Fig. 7).

ADVANTAGES: Lower operating costs in areas with high electricity prices and low gas prices. Avoids the additional electrical service required for a central electric air-conditioning system. Does not use an ozone-depleting refrigerant.

DISADVANTAGES: High initial cost. Limited market infrastructure and service support. More complex systems with greater maintenance requirements.

FURTHER READING

1996 HVAC Systems and Equipment Handbook, Atlanta, GA, American Society of Heating, Refrigerating and Air-Conditioning Engineers, Inc.

Simplified Design of HVAC Systems, William Bobenhausen, New York: John Wiley & Sons, Inc., 1994.

This Old House Heating, Ventilation, and Air Conditioning, Richard Trethewey, Little, Brown and Company, 1994.

PRODUCT INFORMATION

Carrier North American Operations, P.O. Box 4808, Carrier Parkway, Syracuse, NY 13221; 315-432-6000; www.carrier.com.

Cool Tech Industries, Inc., 8230 Post Road, Fair Oaks, CA 95628; 916-536-0902; www.smartcool.com.

Robur Corporation, 2300 Lynch Road, Evansville, IN 47711; 812-424-1800; www.robur.com.

Tamarack Technologies, Inc., P.O. Box 490, West Wareham, MA 02576; 800-222-5932; www.tamtech.com.

Trane Company, 3600 Pammel Creek Road, LaCrosse, WI 54601; 608-787-3111, www.trane.com.

York International Corporation, 631 South Richland Avenue, York, PA 17403; 717-771-7890; www.york.com.

ESSENTIAL KNOWLEDGE

Heat pumps represent a single system that can provide both heating and cooling. A single source of energy — electricity — is typically used, and vents and chimneys for combustion products can be eliminated. Heat pumps were introduced to the residential market in the 1950s and early systems had problems with reliability and comfort. Today's heat pump systems are much more reliable and efficient.

The installation of a new heat pump system as part of a home's rehabilitation should be considered if an existing heat pump is nearing the end of its expected life (15 to 20 years) or the existing heating system needs replacement and the addition of air conditioning is desirable. Heat pumps are a logical HVAC system choice in climates with significant cooling loads and *modest* heating loads. If heating loads are small, a less expensive electric resistance heating and electric air conditioning system may be more logical. If heating loads are large, a gas furnace/air conditioner combination may be the optimum choice.

When cooling, heat pumps use the vapor compression refrigeration cycle just like electric air conditioners (see Section 5). To provide heating, heat pumps are equipped with reversing and check valves to run the cycle backwards, removing heat from the outdoors and dumping it indoors (Fig. 1). Unfortunately, as outdoor temperatures drop and heating loads increase, the capacity of a heat pump declines (Fig. 2). In most climates, a heat pump needs to be equipped with a supplemental heat system, which is typically electric resistance heat.

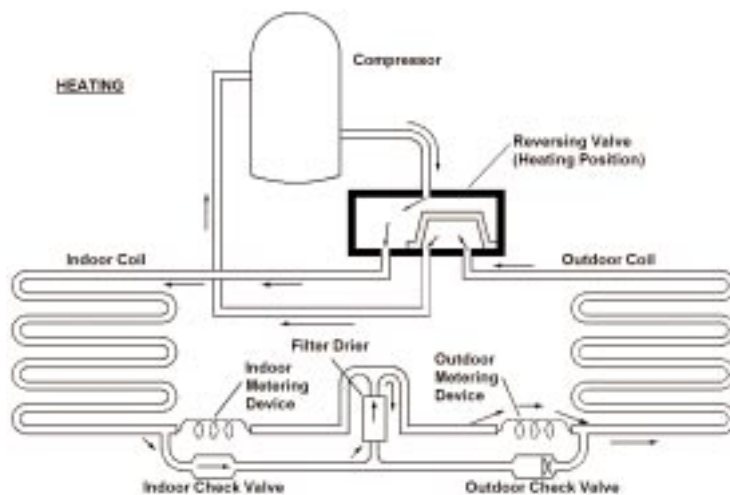

FIGURE 1

HEAT PUMP CYCLE-HEATING MODE

There is a variety of heat pump types, each with different standards for rating efficiency, but the most common rating terms are SEER (Seasonal Energy Efficiency Ratio) for cooling performance and HSPF (Heating Seasonal Performance Factor) for heating performance. The SEER is the same rating method used for air conditioning systems (see Section 5). The HSPF is the ratio of total heating output in Btu of a heat pump during its normal annual usage period to the total electric power input in watt-hours during the same period. It is reported in units of Btu of heating per watt-hour of electric energy con-

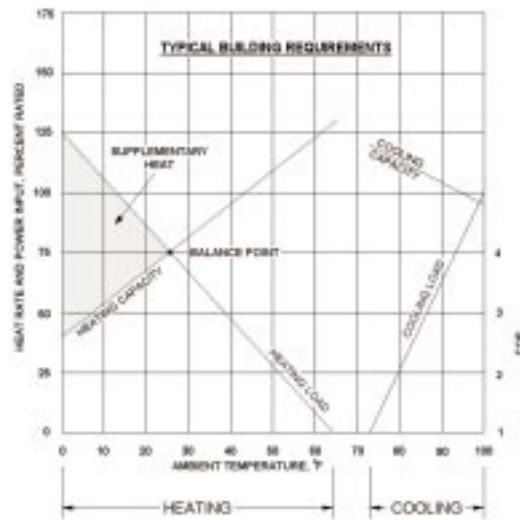

FIGURE 2

HEAT PUMP CAPACITY AND AMBIENT TEMPERATURE RELATIONSHIP

sumption, including the unit's compressor, fans, and controls. The higher the HSPF the more efficient the system. An HSPF of at least 6.8 is required by NAECA for conventional central split-system air-cooled heat pump systems with capacities of five tons or less. However, it should be noted that air-source heat pump heating efficiency varies dramatically with outdoor temperature. If considering a heat pump for a cold climate (i.e., colder than Indianapolis, which is representative of the “typical” used for the rating), a comparison of performance at more severe conditions may be more beneficial than relying on the HSPF comparison. In other words, two heat pumps may have the same HSPF rating, but perform quite differently at cold conditions. Ground-source heat pumps use the Coefficient of Performance (COP) as an efficiency rating rather than HSPF. However, GSHPs do not have the varying conditions that air-source units have so multiplying the COP by 3.4 provides a value that is comparable to the HSPF. Make sure the ground-loop pumping energy is included in the efficiency calculation.

In areas where the cooling load is large relative to the heating load, a heat pump may provide a more comfortable year-round solution than a gas furnace/air conditioner combination. When a furnace is used in combination with an air conditioner in a cooling load dominated climate, a significantly oversized furnace may be required to obtain blower performance that is compatible with the size of the cooling coil. Unless the furnace has a variable or two-speed blower, this will produce short-cycling during the heating season, which compromises comfort.

TECHNIQUES, MATERIALS, TOOLS

1. INSTALL A SPLIT-SYSTEM AIR-SOURCE HEAT PUMP (ASHP).

This is by far the most common residential heat pump system. It is very similar to the split-system air conditioner (see Section 5), but operates in the winter as well to provide heating. The indoor unit has a blower, the heat pump coil, and a supplemental heating section that usually contains electric resistance heating elements. Alternatives to using electric resistance heating during cold periods, when the capacity of the heat pump is insufficient, include hydronic coils from the domestic hot water heater (see Combination System in Section 4) or “add-on” heat pumps. “Add-on” heat pumps are heat pumps added to a gas furnace. The heat pump operates with declining efficiency as outdoor temperatures drop to the point where it becomes more economical to operate the gas furnace. Two-speed heat pumps with multi-speed fans and a two-speed compressor are capable of varying the capacity of the system to better match the load and avoid the inefficiencies of cycling on and off frequently.

ADVANTAGES: Most common heat pump system with a well-established service infrastructure.

DISADVANTAGES: Heating performance drops significantly with colder outdoor temperatures.

2. INSTALL A SINGLE-PACKAGE AIR-SOURCE HEAT PUMP.

If the installation of an outdoor compressor/condenser unit is a problem because of noise, aesthetics, or vandalism, the Insider heat pump manufactured by Consolidated Technology Corporation (Fig. 3) may be a viable solution. This unit, originally designed for manufactured homes, contains all of the components in a single package that is approximately the size of a furnace. A fan is used to draw outdoor air in over the “outside” coil and exhausts it. Another fan draws return air from the space over the “inside” coil and returns the conditioned air to the space.

ADVANTAGES: Easier installation with no outdoor unit and refrigerant lines.

DISADVANTAGES: Noise of compressor within the living space.

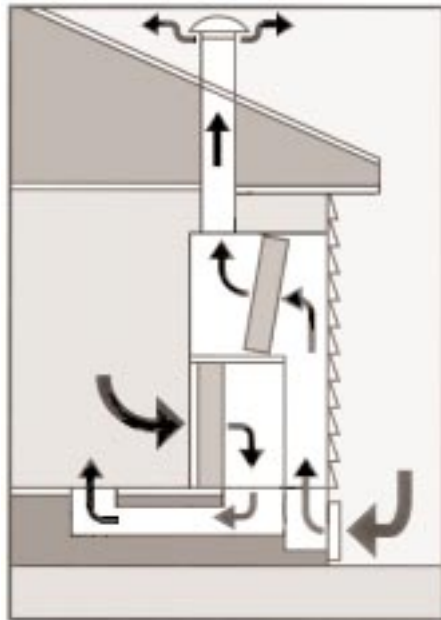

FIGURE 3

SINGLE-PACKAGE AIR SOURCE HEAT PUMP

HEAT PUMP

3. INSTALL A PACKAGED TERMINAL HEAT PUMP (PTHP).

These systems are very similar to PTACs (see Section 5) except they use an electric heat pump to provide heating rather than relying solely on electric resistance for heating.

ADVANTAGES: No ductwork or refrigerant lines to be installed onsite. Zone control capability.

DISADVANTAGES: Units can be noisy and the wall penetrations can be a source of unwanted infiltration.

4. INSTALL ONE OR MORE DUCTLESS SPLIT SYSTEMS OR MINI-SPLITS.

These systems are similar to conventional split systems in that they have an outdoor condenser unit and an indoor evaporator/air handler unit connected by refrigerant piping. However, the indoor unit is located directly in or adjacent to the conditioned space. There is no ductwork required for distributing the air. Several indoor units can be used in conjunction with a single outdoor unit (Fig.4).

ADVANTAGES: Easier to install than ducted systems if no ducting is already in place. Zone control capability. Can be linked with motion detectors to minimize operating time.

DISADVANTAGES: Operate on recirculated air only and have no means for providing fresh air. Although very popular in Japan and Europe, they are not widely used or manufactured in the U.S.



FIGURE 4

DUCTLESS SPLIT SYSTEM

5. INSTALL A GROUND-SOURCE HEAT PUMP (GSHP).

As the name implies, GSHPs use the ground as the source for heat during the winter rather than outdoor air (Fig. 5). They can be an attractive option to ASHPs in colder climates where the ground temperature is warmer and less variable than the air temperature. In the more common closed-loop design, a ground loop of polybutylene or high-density polyethylene pipe is buried and water or antifreeze solution is pumped through it to absorb heat. The pipe can be buried vertically or horizontally, straight or coiled like a “slinky.” Installation will depend on soil conditions, drilling versus trenching costs, and space availability. Open-loop systems pump ground water from a well through a heat exchanger and then discharge it. They avoid the cost of a buried ground loop, but have to address water quality and code issues. Some GSHPs include desuperheaters (see Section 10) for water heating as an integral part of the system.

ADVANTAGES: Usually more efficient on a seasonal basis than ASHP because the ground temperature is higher than the air temperature. GSHPs do not need to defrost like ASHPs.

DISADVANTAGES: Installation cost of the ground loop.

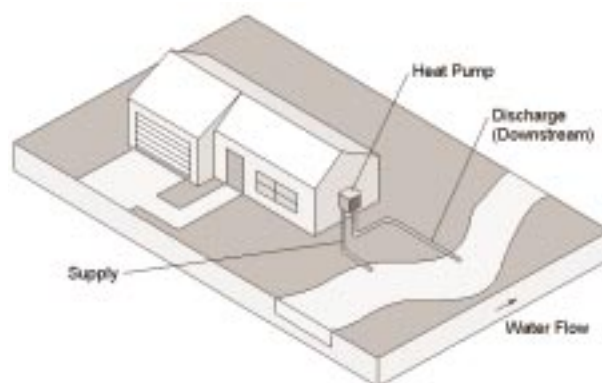
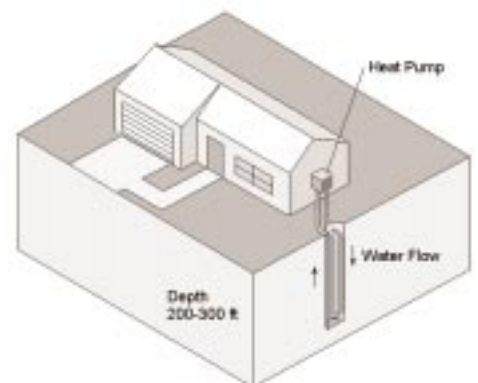

FIGURE 5

OPEN LOOP GSHP



CLOSED LOOP GSHP

FURTHER READING

1996 HVAC Systems and Equipment Handbook, Atlanta, GA, American Society of Heating, Refrigerating and Air-Conditioning Engineers, Inc.

ARI Directory of Certified Applied Air-Conditioning Products, Arlington, VA, Air-Conditioning & Refrigeration Institute.

Closed-Loop/Ground-Source Heat Pump Systems: Installation Guide, Stillwater, OK, International Ground-Source Heat Pump Association, 1988.

PRODUCT INFORMATION

Carrier North American Operations, P.O. Box 4808, Carrier Parkway, Syracuse, NY 13221; 315-432-6000; www.carrier.com.

Consolidated Technology Corporation, P.O. Box 1537, Olive Hill, KY 41164; 606-786-5366.

EMI Corporation, 5780 Success Drive, Rome, NY 13440; 315-336-3716; www.enviromaster.com

Trane Company, 3600 Pammel Creek Road, LaCrosse, WI 54601; 608-787-3111, www.trane.com.

WaterFurnace International, Inc., 9000 Conservation Way, Fort Wayne, IN 46809; 800-222-5667; www.waterfurnace.com.

York International Corporation, 631 South Richland Avenue, York, PA 17403; 717-771-7890; www.york.com.

INDOOR AIR QUALITY

ESSENTIAL KNOWLEDGE

As homes constructed since the 1980s have become “tighter” in order to reduce infiltration to improve comfort and save energy, concerns about indoor air quality have grown. The list of indoor pollutants is long, but the most common include: formaldehyde fumes from building materials, furniture, curtains, and carpet; organic gases from aerosols, paints, solvents, and air fresheners; carbon monoxide and nitrogen dioxide from unvented appliances such as gas ranges; dust mites, mold spores, and mildew.

Tight homes without a mechanical ventilation system can depressurize when devices such as exhaust fans or clothes dryers operate and remove air from conditioned space. Depressurization can cause back-drafting of combustion appliances and potentially increased radon levels (Fig. 1).

The simplest way to improve indoor air quality is through a controlled ventilation system. Mechanical ventilation systems are now required in new homes by some building codes, particularly in the Northwest and Canada. The recommended amount of ventilation air is a subject of debate by experts in the field. The American Society of Heating, Refrigerating and Air-Conditioning Engineers (ASHRAE) Standard 62 recommends 15 cfm of outside air per person or 0.35 air changes per hour (ACH) for residences. This standard has been controversial and is under revision. A proposed revision uses 5 cfm per 100 square feet of house area. The Home Ventilating Institute (HVI), a ventilation equipment trade organization, recommends 0.5 ACH.

Ventilation systems assure that adequate fresh air is brought into the home to replace the indoor air that is removed. There are several different mechanical ventilation approaches. In addition to mechanical ventilation for indoor air quality, humidifiers and dehumidifiers may be installed to control humidity and air cleaners can be used for those sensitive to air contaminants such as dust and pollen.

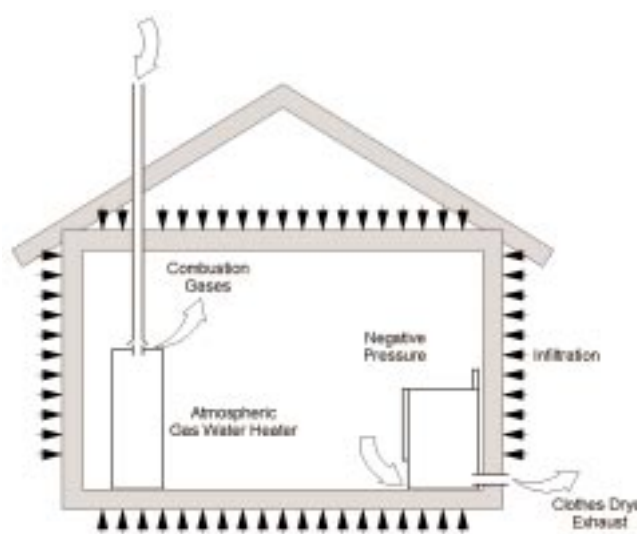

FIGURE 1

DEPRESSURIZATION INDUCED BACK-DRAFTING

1. INSTALL A MECHANICAL VENTILATION SYSTEM.

There are three basic types of mechanical ventilation systems: exhaust, supply, and balanced (Fig.2). Exhaust and supply systems typically use a single fan that either pulls air from the home or pushes air into the home in conjunction with intentional air inlets or pressure relief outlets. These systems either depressurize or pressurize the home. Depressurization can cause problems with combustion appliance backdrafting and potentially increased radon infiltration. Pressurization can promote detrimental moisture infiltration into building materials. To avoid these problems, balanced mechanical ventilation systems typically use at least two fans, supply and exhaust, to maintain a neutral pressure in the home. The most energy-efficient type of balanced mechanical ventilation system is a heat recovery ventilator or air-to-air heat exchanger (Fig.3). These systems include a heat exchanger to exchange heat between the exhaust and supply air streams. Fresh supply air is preheated in the winter and precooled in the summer. Among the manufacturers of these types of systems is Nutech Energy Systems, which has introduced the Lifebreath Clean Air Furnace (Fig.4), designed to draw in outside air at a rate that is approximately 10% of the total supply air flow. In regions with significant moisture differences between supply and exhaust airstreams, enthalpy wheels may be used as the heat exchanger. The wheels include a desiccant material on a heat wheel to absorb and release moisture and heat.

ADVANTAGES: Better health and safety because the supply of an adequate amount of fresh air to the home is assured.

DISADVANTAGES: Initial installation and fan operating cost can be high. Filter maintenance is required. Additional heating and cooling loads are placed on the existing heating and cooling system. Additional load is minimal with heat or enthalpy recovery ventilators.

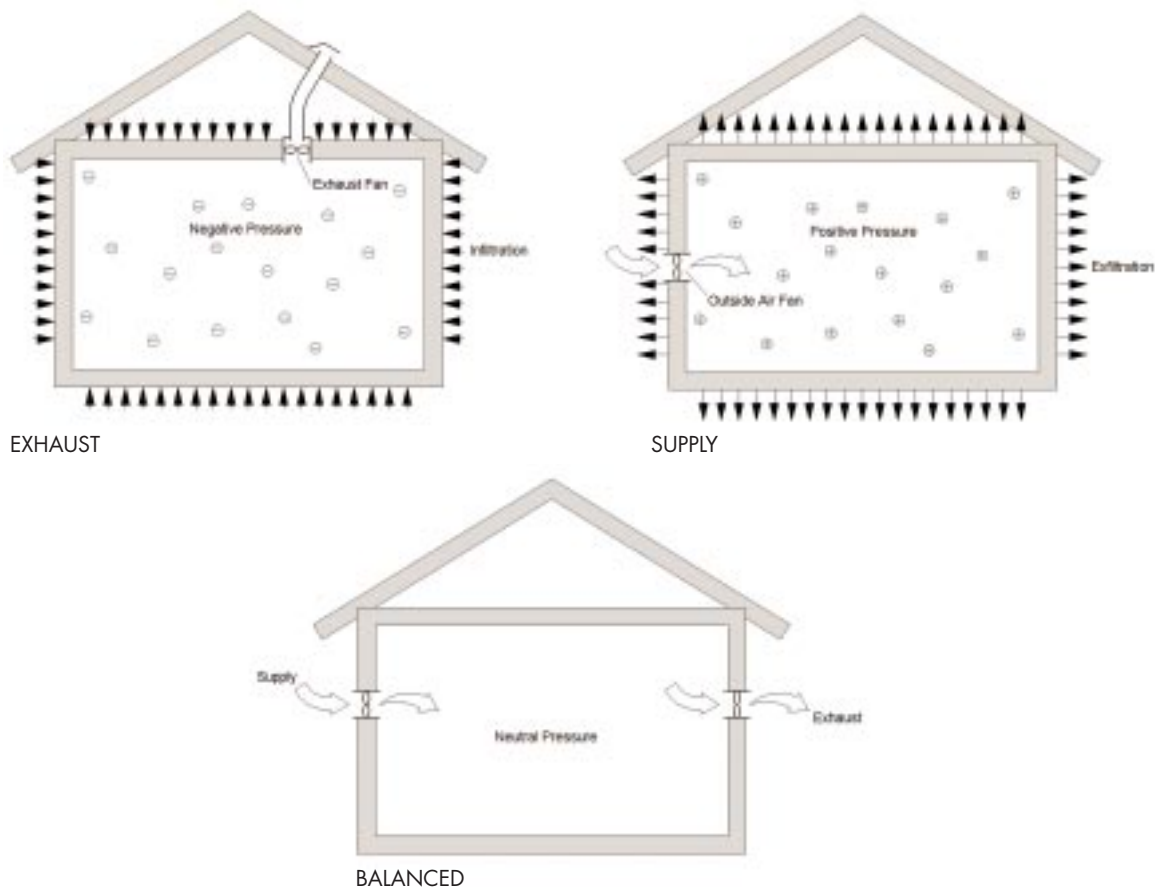

FIGURE 2

MECHANICAL VENTILATION TYPES

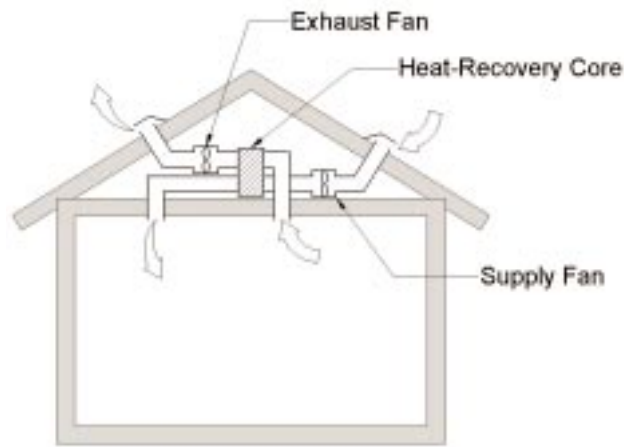

FIGURE 3

BALANCED SYSTEM WITH A HEAT RECOVERY VENTILATOR

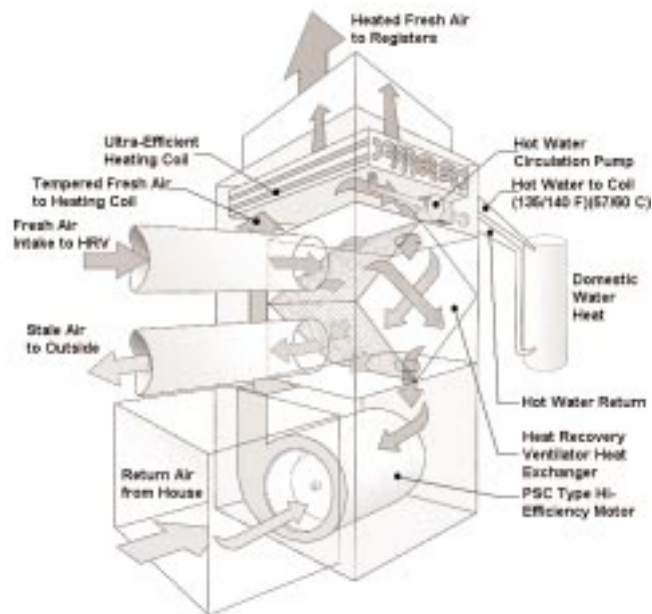

FIGURE 4

LIFEBREATH CLEAN AIR FURNACE

2. INSTALL A HUMIDIFIER.

Low indoor humidity can be problematic in cold climates during the heating season. Cold, winter air holds less moisture than warm summer air (80°F air at 50% RH contains twice as much water as 42° F air at 100% RH). Low indoor relative humidity can lead to dry skin, nosebleeds, and respiratory problems. An indoor relative humidity of 35 to 50% is recommended. There are three basic humidifier types for residential applications: pan, wetted-element, and steam. Ultrasonic and impeller-type humidifiers, which emit a mist into the air, are discouraged because they require the use of demineralized or distilled water to avoid circulating harmful minerals into the air. Whole-house humidifiers are used in conjunction with a warm-air furnace. Pan-type humidifiers use a pan of water in the furnace plenum. As warm air flows over the pan, water evaporates into the air. A heating element can be used to increase the water temperature and the rate of evaporation and/or wicking plates can be used to increase the pan's effective surface area (Fig. 5). Wetted-element humidifiers use a plastic pad that rotates through a reservoir of water (Fig. 6). As air passes through the pad, water evaporates into the air stream. Steam humidifiers use heating elements to boil the

water in a pan. They provide higher humidification output than other humidifier types. Honeywell produces a steam humidifier for residential applications that independently controls the furnace fan to provide humidified air to the space even when the furnace is not running to supply heat. An issue with all types of humidifiers is disposal of mineral deposits that accumulate in the water reservoir. Automatic flushing systems are available, but require a drain and use more water. Humidifiers without a flushing system should be cleaned routinely, every one or two months, to remove the deposits. Humidistats are typically used to control humidifiers. Research Products has introduced an Aprilaire whole-house humidifier that monitors the outdoor humidity and automatically provides the optimum humidity to the home.

ADVANTAGES: Higher, more comfortable heating season humidity allows lower thermostat settings without sacrificing comfort (for example, air at 69°F and 35%RH provides the same level of comfort as 72°F and 19%RH).

DISADVANTAGES: If improperly controlled, excessive indoor humidity can cause damaging condensation problems. Maintenance required to remove mineral deposits on non-flushing systems.

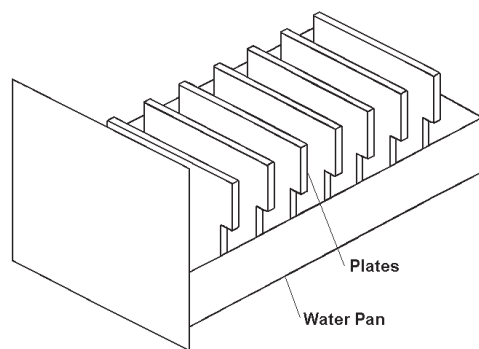

PAN HUMIDIFIER

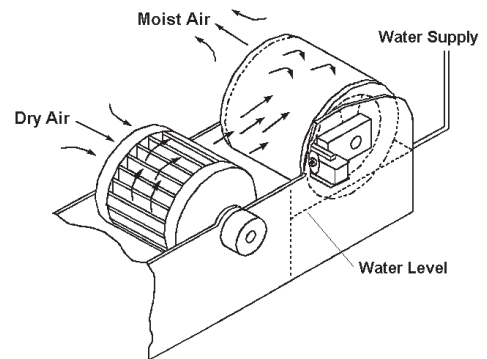

WETTED-DRUM HUMIDIFIER

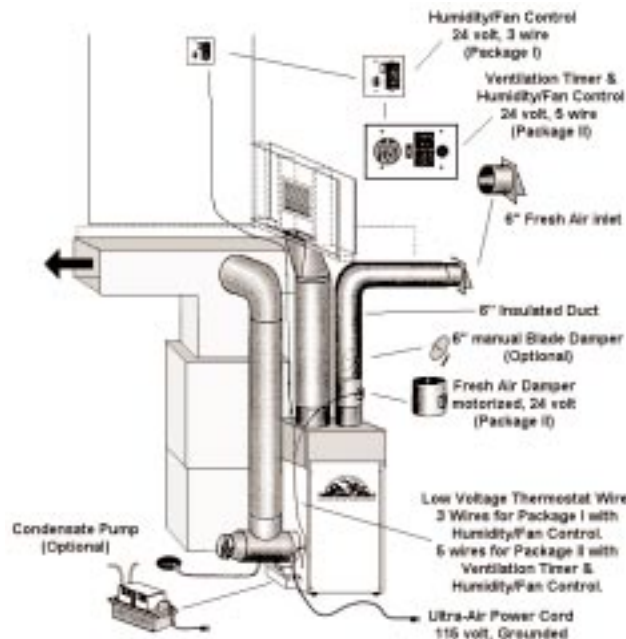

ULTRA-AIRE PURIFYING DEHUMIDIFIER

FIGURE 5, 6

FIGURE 7

3. INSTALL A DEHUMIDIFIER.

High levels of indoor humidity cannot only cause comfort problems, but also health concerns with the potential for increased growth of mold and bacteria. In severe situations, building materials and furnishings can be damaged by mildew.

High levels of humidity can occur in a tight home when internally generated moisture by people, cooking, or showering is not exhausted. Condensation on the inside of cold windows and within wall insulation in the winter can be damaging. Bath fans such as the SmartSense by Nutone automatically activate when high humidity levels are detected.

High humidity levels can also occur in the summer if the ventilation system introduces humid outside air to the conditioned space. Dehumidifiers appropriate for residential applications employ refrigeration to cool the air below its dew point to remove moisture. This process also might cool the air lower than desired. The cool, dry air can be reheated by passing it over the unit's condenser coil. There are several manufacturers of these types of systems, such as Therma-Stor Products' Ultra-Aire Air Purifying Dehumidifier, which combines a dehumidifier with an outdoor air inlet for ventilation air and an optional 95% efficient pleated media filter (Fig. 7).

ADVANTAGES: Humidity is properly controlled independent of temperature. At lower indoor humidities, thermostat settings can be raised to achieve the same level of comfort.

DISADVANTAGES: Can be costly to install and operate.

4. INSTALL AN AIR FILTER OR CLEANER.

People who are particularly sensitive to air contaminants such as dust and pollen, may benefit from a high-efficiency air filter or air cleaner. Air pollutants are either a particulate or a gas and there are specific types of filters for each category. Particulate pollutants include mold spores, pollen, house dust, animal dander, clothing and furnishing fibers, and dirt. Most filters are designed for particulate removal. Gases include combustion gases, by-products of human and animal metabolism, and volatile organic compounds. Adsorption type filters such as charcoal are used for gas pollutants. Tobacco and wood smoke are both particulates and gases and require a combination of filter types. The standard filter in a furnace or air-conditioning system is typically only good for fairly large particulates. A test for determining the efficiency of a filter is the atmospheric-spot-dust test, which measures particles between 0.3 and 6 microns in size. A standard 1"-thick furnace filter may only be 3 to 5% efficient according to an atmospheric-spot-dust test. The standard furnace/air conditioner filter is a media filter because it is made of material that is designed to trap particulates. The higher the media filter efficiency, the greater the initial cost and operating cost due to higher pressure drop and thus fan energy requirements.

Another type of air filter, an electrostatic precipitator, gives particulates a static-electric charge to capture them. The charged particulates are then collected by oppositely charged metal plates. Electrostatic precipitators are often rated at 90% efficiency (atmospheric-spot-dust test), but the metal plates must be cleaned often to maintain efficiency. These types of air filters also produce small amounts of ozone that can then be captured in a subsequent adsorption filter. They do not have the pressure drop problem of media filters. Electrostatic air filters are media filters that use a special fibrous plastic material that becomes charged as air passes through (Fig. 8). Oppositely charged particles in the airstream then cling to the filter media. They are about 10 to 15% efficient (atmospheric-spot-dust-test), but have a lower pressure drop penalty than a 30 to 60% efficient medium-efficiency media filter.

Complete air cleaning systems will include a particulate filter and an adsorption filter. There are also systems that address the need for ventilation air. Therma-Stor Products manufactures the Filter-Vent System that brings in outside air, combines it with indoor air, and draws the mixed air through a 90 to 95% media filter and an activated carbon filter.

ADVANTAGES: The only method of providing pollutant-free indoor air in an area with high levels of outdoor pollutants and/or for those occupants who are especially sensitive.

DISADVANTAGES: High maintenance. Uncleaned media filters produce an excessively high pressure drop. An uncleaned electrostatic precipitator or filter will be ineffective. High initial and operating costs. Air cleaners alone do not bring in outside air so they are not a substitute for a ventilation system.

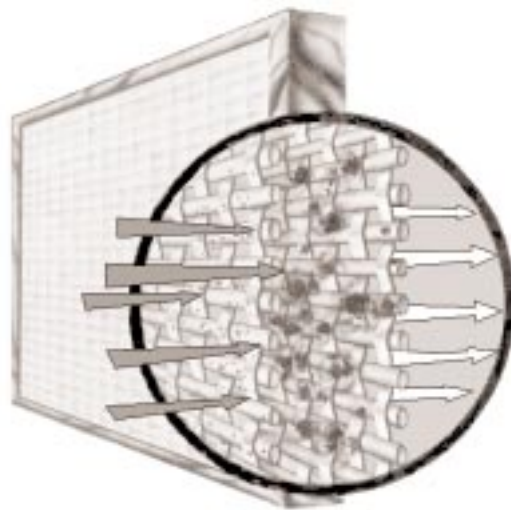

FIGURE 8

ELECTROSTATIC AIR FILTER

FURTHER READING

ASHRAE Standard 62-1989, Ventilation for Acceptable Indoor Air Quality, Atlanta, GA, American Society of Heating, Refrigerating and Air-Conditioning Engineers, 1989.

Certified Home Ventilating Products Directory, Home Ventilating Institute, Division of AMCA, 30 West University Drive, Arlington Heights, IL 60004; 847-394-0150.

Understanding Ventilation, John Bower, The Healthy House Institute, 1995.

PRODUCT INFORMATION

American Aldes Ventilation Corporation, 4537 Northgate Court, Sarasota, FL 34234; 800-255-7749; www.oikos.com/aldes.

Honeywell, Inc., 1985 Douglas Dr. North, Golden Valley, MN 55422; 800-328-5111; www.honeywell.com.

Nutech Energy Systems, Inc., 270 Regency Ridge, Suite 210, Dayton, Ohio 45459; 937-439-6676; www.lifebreath.com.

Research Products Corporation, 1015 East Washington Avenue, P.O. Box 1467, Madison, WI 53701; 800-545-2219; www.resprod.com.

Therma-Stor Products, P.O. Box 8050, Madison, WI 53708; 800-533-7533; www.thermastor.com.

Trion, Inc., P.O. Box 760, Sanford, NC 27331; 919-775-2201; www.trioninc.com.

ESSENTIAL KNOWLEDGE

A critically important aspect of an HVAC system's ability to efficiently maintain comfort is its controls. Today, nearly all heating and/or cooling systems are controlled by a thermostat. Even factory-built wood fireplaces are available with thermostat control. The sophistication of thermostats and other HVAC system controls has evolved dramatically over the last decade with the advancement of electronic controls. As controls for residential systems are relatively inexpensive, and their technology has advanced significantly in the past few years, it is cost effective to replace older controls that may not be operating properly.

A thermostat senses the room air temperature and controls the heating system via an electrical switch according to an occupant-selected setpoint temperature. Line voltage thermostats are typically used for zonal electric resistance heating systems and low voltage thermostats are used for central systems. Thermostats should be located about 5' above the floor where they will sense an air temperature representative of the room or area being controlled. Location near a heat source such as the supply register or heat sink such as a window will result in poor comfort control.

Old-style electromechanical thermostats found in many rehab projects employ either a mercury or snap-action switch, a bimetallic coil, and an anticipator (Fig. 1). The bimetallic coil expands and contracts as it heats and cools, activating and deactivating the switch that controls furnace or boiler operation. The anticipator is a tiny heater that heats the bimetallic coil to compensate for its slow response to changing air temperature. Adjustment of the thermostat dial establishes the angle or the tension of the bimetallic coil to the contacts. There are versions of these thermostats that include an electric clock to switch the thermostat between two temperature settings to achieve an energy-saving setback condition. An eight-hour overnight setback during the heating season saves 1% to 2% per degree of setback. An eight-hour midday setup during the cooling season saves 1% to 3% per degree of setup.

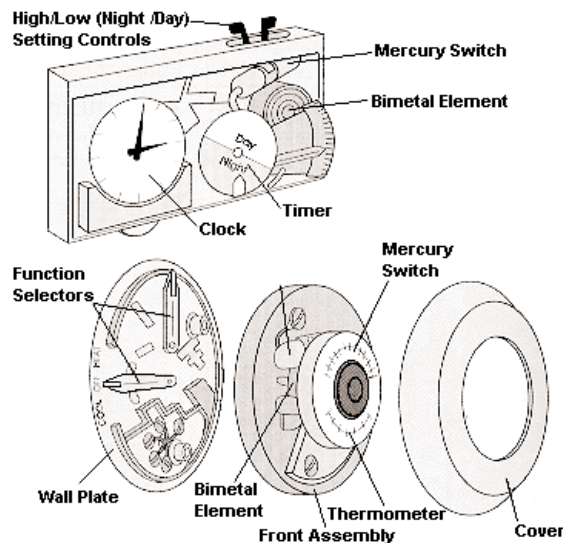

FIGURE 1

ELECTRICAL THERMOSTAT

1. REPLACE THE BIMETAL THERMOSTAT WITH AN ELECTRONIC PROGRAMMABLE THERMOSTAT.

While electromechanical thermostats (Fig. 2) are lower in cost than electronic programmable thermostats, their performance in terms of “deadband” and “droop” is poorer as well. Deadband is an indicator of the swing in room temperature between heating/cooling system cycles. Droop is an indicator of how well the anticipator is functioning. Thermostats also degrade over time as calibration slips and mechanical parts stick. An old electromechanical thermostat can be cleaned and recalibrated, but a better solution is to simply replace it with a new electronic thermostat. Electronic thermostats employ a thermistor rather than a bimetallic coil for sensing the room air temperature. It is more sensitive and fast responding. Microprocessor programming allows for several different temperature settings throughout the day and for different days of the week. Some units provide for different settings for weekdays and weekends or weekdays, Saturdays, and Sundays. The Lightstat thermostat has the ability to adjust the thermostat setting using the light level in the room as an indicator of whether people are in the room. Honeywell has a thermostat that senses lighting levels and occupancy. Thermostats are also now available as wireless remote control devices. They may be placed on the coffee table in the center of the room next to the television remote. Home Automation manufactures a line of thermostats that can communicate with home automation systems, personal computers, and utility demand-side management programs. In a region with real-time pricing, the RC-91 model has the ability to display the real-time energy price and the user can then set the thermostat accordingly.

ADVANTAGES: Energy savings through more capability to set back temperature during unoccupied or night time hours. More accurate and responsive for better comfort control.

DISADVANTAGES: Somewhat higher cost. Just like VCRs, there may be some homeowners that have difficulty following the sequential steps to program them properly. Some types of heat distribution systems such as radiant and hydronic baseboard systems are not as responsive as forced air and the time required to recover from a thermostat setback may be unacceptable.



FIGURE 2

ELECTRONIC PROGRAMMABLE THERMOSTAT

2. INSTALL A HUMIDISTAT.

Typically, heating and cooling systems are designed to maintain comfort in terms of temperature only. Humidity is allowed to fluctuate. In warm humid climates, it may be desirable to control the air conditioning system to maintain comfort humidity as well as temperature conditions. In colder climates, a humidifier may be installed to maintain higher and more comfortable indoor humidity levels. In either sit-

uation, the installation of a humidistat (or dehumidistat, depending on the situation) is appropriate. The location of the humidistat can vary. It can be in the room next to, or integral with, the thermostat or in the return air duct. The humidistat works in a similar manner to the thermostat. It senses humidity and turns the air conditioner or humidifier on or off based upon a humidity setpoint. For two-speed air conditioners, the dehumidistat may trigger the system to go to low speed for enhanced dehumidification capability. **ADVANTAGES:** Better control of humidity for improved comfort and air quality. **DISADVANTAGES:** Calibration needs to be checked periodically. When controlling an air conditioning system in humid climates, can cause over-cooling.

3. INSTALL A CONTROL SYSTEM THAT SENSES OUTDOOR CONDITIONS AND ADJUSTS ACCORDINGLY.

More sophisticated control systems incorporate outdoor temperature sensors as well as indoor sensors for better control and operating efficiency. For heat pump systems equipped with auxiliary electric resistance heat, an outside temperature sensor is used to lock out the resistance heat when the outdoor temperature is above a specific setting. This prevents the resistance heat from unnecessarily coming on to quickly recover from a nighttime setback. Outdoor temperature sensors are also used to adjust the water temperature in hydronic systems to the lowest temperature necessary to meet the home's heating load. For the control of humidifiers in cold climates, Honeywell Comfort Center's winter humidity control senses outdoor temperature and resets the indoor humidity setting accordingly to prevent condensation on windows. The Honeywell system can be customized for the insulating value of the home's windows. Aprilaire also has a humidistat that controls according to outdoor temperature but does not have the window customization capability.

ADVANTAGES: Reduced operating costs for the heat pump auxiliary heat lock out control. **DISADVANTAGES:** Higher initial cost.



VENTILATION CONTROLLER



MOTORIZED OUTSIDE AIR DAMPER

FIGURE 3

4. INSTALL VENTILATION SYSTEM CONTROLS.

There is a variety of methods for controlling mechanical ventilation systems. On the simple, low cost end of the spectrum are the manual controls. These include a simple on/off switch. Additional features might be a timer that shuts the fan off automatically after a certain period of time or a speed control that allows the user to select the ventilation air flow. The manual controls rely upon the user recognizing when ventilation is needed and taking the appropriate control action. The average human nose is more sensitive to air pollutants than most sophisticated electronic sensors. Another set of control options that are more sophisticated and more expensive are automatic. These include time clocks programmed by the user. Trol-A-Temp's Timed Make-Up Air Control (TMAC) or Timed Ventilation Control (TVC) are simple timers that control a motorized damper that allows outside air into the central HVAC system (Fig. 3). The unit will turn on the HVAC blower if it is not already running. Automatic controls also include a variety of demand-controlled ventilation (DCV) strategies. The DCV methods rely upon a sensor in the space or return duct to detect when additional ventilation air is needed. The sensing parameter can be motion, humidity, car-

bon dioxide, or a mixture of gaseous pollutants such as tobacco smoke, cooking odors, and VOCs. For the most part, the manual controls tend to be most appropriate for local exhaust fans and the more sophisticated automatic controls are appropriate for whole-house ventilation systems.

ADVANTAGES: Manual controls are relatively inexpensive and reliable. Automatic controls do not rely upon the user.

DISADVANTAGES: Manual controls rely upon the user for proper control. Automatic controls are more expensive and can fall out of calibration resulting in either insufficient or excessive ventilation air quantities.

5. INSTALL A FORCED-AIR ZONING SYSTEM.

Forced-air zoning systems utilize thermostats in conjunction with motorized dampers in individual supply ducts to different control zones (Fig. 4). By varying the air flow in response to the zone thermostat, a single air conditioning and/or heating system can be used to meet the varying needs of multiple zones. These systems are most easily installed in a new installation, but can be retrofitted into an existing system. Care must be taken to either bypass extra air or oversize the ductwork to assure that central system air flow does not drop below the design minimum when only one or two zones are calling for air and all other zones are closed. There are several manufacturers of this type of system including Research Products Corporation, Carrier, Honeywell/Trol-A-Temp and Durazone.

ADVANTAGES: Achieves the energy saving and improved comfort benefits of zoning with a central forced-air system.

DISADVANTAGES: High initial cost. Systems need to be carefully designed to assure that minimum air flow requirements are met under all operating conditions.

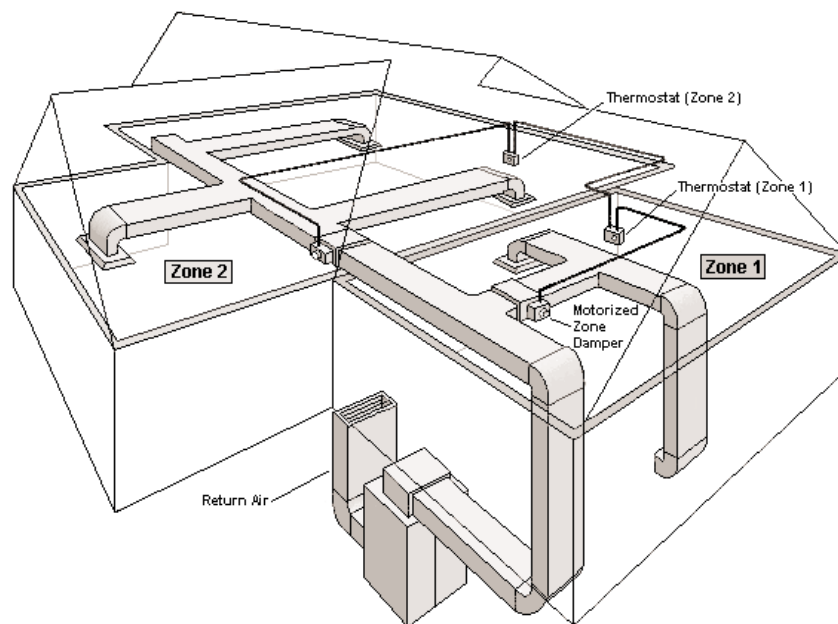

FIGURE 4

FORCED-AIR ZONING SYSTEM

FURTHER READING

Comfort, Air Quality, and Efficiency by Design, Manual RS, Air Conditioning Contractors Association, 1997.

Understanding Ventilation, John Bower, The Healthy House Institute, 1995.

PRODUCT INFORMATION

Broan Mfg. Co., Inc., P.O. Box 140, Hartford, WI 53027; 800-548-0790; www.broan.com.

Carrier North American Operations, P.O. Box 4808, Carrier Parkway, Syracuse, NY 13221; 315-432-6000; www.carrier.com.

Home Automation, Inc., 2709 Ridgelake Drive, Metairie, LA 70002; 800-229-7256.

Honeywell, Inc., 1985 Douglas Dr. North, Golden Valley, MN 55422; 800-328-5111; www.honeywell.com.

Lightstat, Inc., 22 W. West Hill Road, Winsted, CT 06098; 800-292-2444; www.lightstat.com.

Robertshaw, Uni-Line North America, Division of Siebe Climate Control, P.O. Box 2000, Corona, CA 91719; 909-734-2600; www.robertshaw.com.

Tamarack Technologies, Inc., 11 Patterson's Brook Rd., West Wareham, MA 02576; 800-222-5932; www.tamtech.com.

Trol-A-Temp, Division of Trolex Corp., 57 Bushes Lane, Elmwood Park, NJ 07407; 800-828-8367; www.trolatemp.com.

9

FIREPLACES & CHIMNEYS

ESSENTIAL KNOWLEDGE

In recent years fireplaces have captured a renewed interest as a supplemental heating source for the home. In a rehabilitation project, rehabilitating an existing fireplace or installing a new fireplace may be under consideration. The rehabilitation of an existing fireplace cannot only add to the appearance of the room, but also provide for safe and efficient space heating. The installation of a new, efficient fireplace to supplement an existing system, which may be inefficient and/or undersized, may be an attractive alternative to replacing the existing system.

Traditional wood-burning fireplace designs are not efficient, can produce emissions that are harmful to the environment, and, if poorly designed or maintained, can be dangerous. In fact, some Western municipalities in the U.S. have passed ordinances prohibiting the installation of a conventional fireplace for environmental reasons. EPA-approved, factory-built wood and gas fireplaces, wood stoves, or gas-fired logs are acceptable alternatives which should be considered during a rehabilitation project.

If constructing or significantly reconstructing a fireplace or installing a stove, building codes should be carefully reviewed for minimum requirements for materials, heights, and clearances. Local code requirements apply even if the existing chimney is used. If an old unused fireplace is found encased in plaster during the course of a rehabilitation project, it can be reconstructed by a competent mason who knows and follows recommended design practices. Many early fireplaces and chimneys smoked too much due to flaws in their design. This poor performance may be the reason that the fireplace had been abandoned. If an old, closed-off chimney is to be rehabilitated, make sure that it still runs through the roof to an appropriate height and that openings for other stove pipes have not been cut into it. Old chimneys were often used to serve multiple stoves with a single flue.

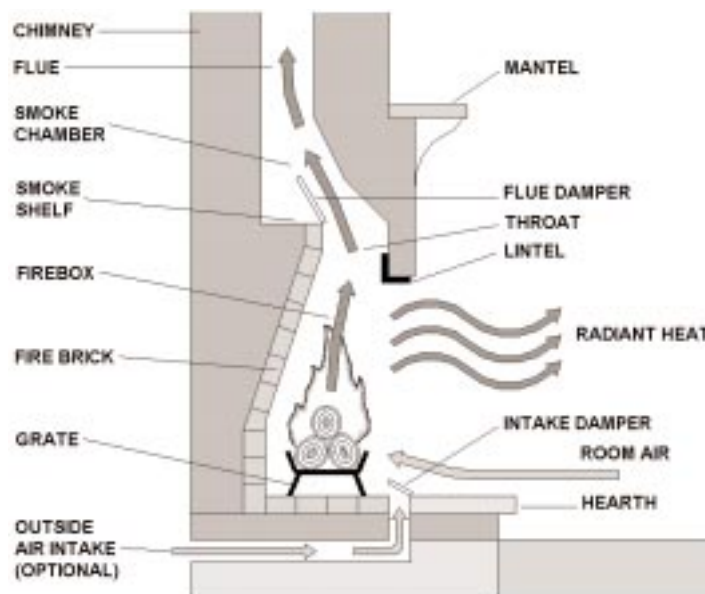

FIGURE 1

CONVENTIONAL WOOD-BURNING FIREPLACE

Conventional fireplaces (Fig. 1) provide heat primarily by radiation. Thus, the amount of brick masonry, surface area exposed to the fire, its distance from the fire and the size of the fire determine the amount of heat provided. Rumford-style fireplaces feature angled side walls, a shallow depth, and a high opening. These fireplaces tend to be more efficient than conventional designs because they radiate more heat and draw less room air up the chimney. Air-circulating fireplaces (Fig. 2) capture heat from the back of the firebox by circulating room air through brick baffles or steel plates. This warmed air can then be circulated by a fan to spaces to provide heat by convection.

The primary function of a chimney flue is to exhaust combustion wastes - carbon dioxide, nitrogen, sulfur dioxide, water vapor, and carbon monoxide. A second function is to create a draft that pulls the air over the fire. For a wood-burning fire, the draft must be strong. To accomplish this, the fireplace has a sloped back and a stepped throat controlled by a damper. Each combustion heat source (e.g., furnace and fireplace) needs its own flue, but a single chimney can contain several flues from multiple fireplaces and/or a furnace. (Fig. 3) Two combustion appliances such as a water heater and a furnace can share a flue. In this instance, problems can arise if one of those appliances is replaced with a direct-vent unit because the flue is too large for the remaining appliance. Condensation of combustion gases can occur in the chimney, resulting in corrosion. This can also occur with the installation of a higher efficiency chimney-vented combustion appliance, particularly in a cold climate.

Beyond replacing the brick and mortar of an old disintegrating chimney, clearing several inches of debris from above the damper, and clearing other blockages in the chimney flue, several additional steps may be necessary to assure that an old fireplace and chimney are in safe working condition. Alternatives or enhancements to the fireplace such as stoves and inserts can also improve the efficiency of the system.

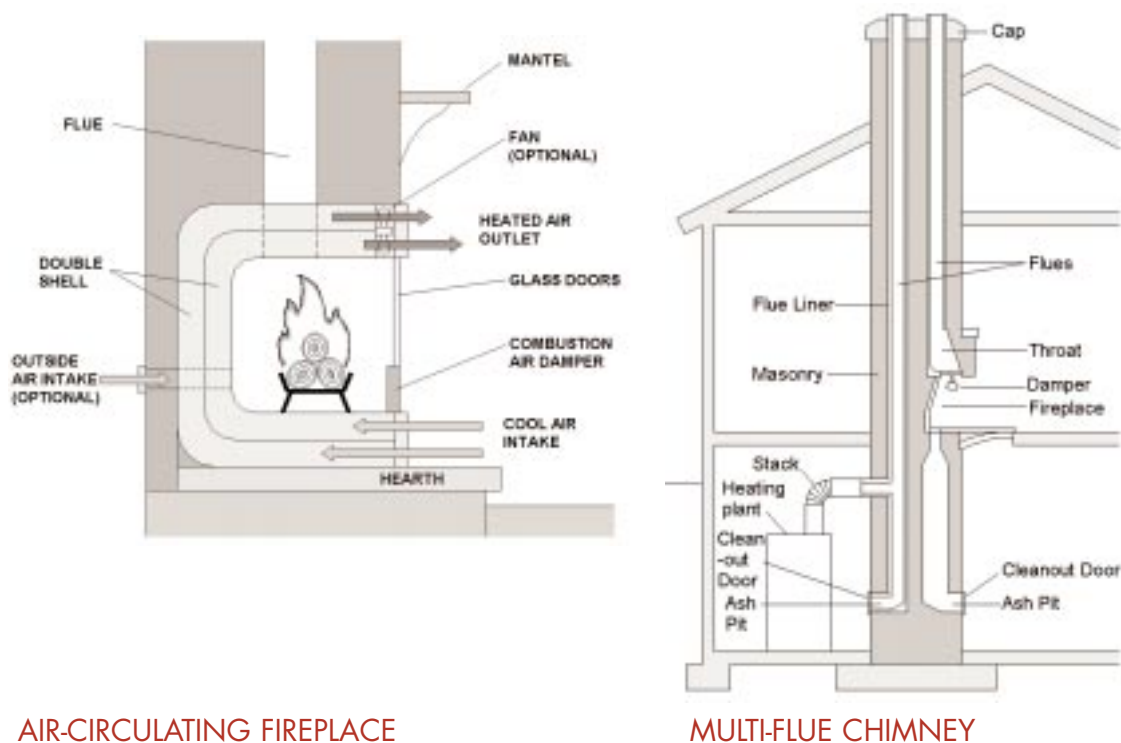

FIGURE 2, 3

AIR-CIRCULATING FIREPLACE

MULTI-FLUE CHIMNEY

TECHNIQUES, MATERIALS, TOOLS

1. REBUILD OR REPOINT THE CHIMNEY.

The mortar between the bricks of an old chimney is likely to be in need of renewal. It was not intended to last as long as the bricks. The replacement process is known as repointing or tucking. Whatever kind

of mortar was used initially should be used for repointing so as to have the same expansion and compression characteristics under varying weather conditions. In some instances, the condition of the chimney may have deteriorated to a point beyond repair by repointing and relining. When the mortar crumbles easily and/or bricks are loose, removal and replacement should be considered. It may be possible to reuse the original bricks. Creosote is a carcinogen so a respirator should be worn when rehabilitating an old chimney and the work area should be enclosed in plastic sheeting to protect the rest of the house.

ADVANTAGES: Improved safety and integrity of the chimney.

DISADVANTAGES: Can be expensive because it is a time consuming process that requires the expertise of a mason.

2. INSTALL A CHIMNEY CAP.

Rain mixing with soot and fireplace gases produces a destructive acid. Thus, all chimneys should have a rain cap to prevent this deterioration (Fig. 4). Rain caps can also minimize downdrafts.

ADVANTAGES: Fairly inexpensive. Extends the life of the chimney.

DISADVANTAGES: Difficult to install on high chimneys.



FIGURE 4

CHIMNEY CAP

3. RELINE THE CHIMNEY.

Liners, which are now required by code, prevent the heat from a chimney fire from causing a house fire. Older chimneys may be unlined (pre-1910), lined with mortar that has deteriorated, or have old tile liners that are cracked. They also often served more than one fireplace and had more than one flue in them with a wall of brick as a divider. This brick divider is likely to be in very poor condition and tumbling bricks from this divider can block the flue.

The solution to all of these problems is to reline the chimney. There are different methods for relining a chimney.

■ Install a metal pipe available in 3 ft. sections from local heating suppliers. Stainless steel should be used if the flue will be used for furnace gases, which are very corrosive. Seal around the pipe at the bottom and top of the chimney with lightweight mortar. Flexible pipe is also available for non-straight chimneys. Caution is advised if the chimney has a weak draft. Reducing the cross-section area of the flue with a metal pipe will only worsen the situation.

■ Install a tile lining. This is required by code in some areas if the chimney is to be used with wood fires. Although more expensive, a tile liner is more resistant to corrosion and the high temperatures of a chimney fire due to creosote build up.

■ Use a patented process, which is only available through franchised dealers, to line the chimney with a cementitious mix. A vinyl or rubber hose can be inserted and inflated (Fig. 5). Lightweight concrete is then poured around the hose, which is deflated and removed after the concrete sets.

ADVANTAGES: Improved safety and integrity of the chimney.

DISADVANTAGES: Can reduce the size of the flue and thus the draft to an insufficient level.

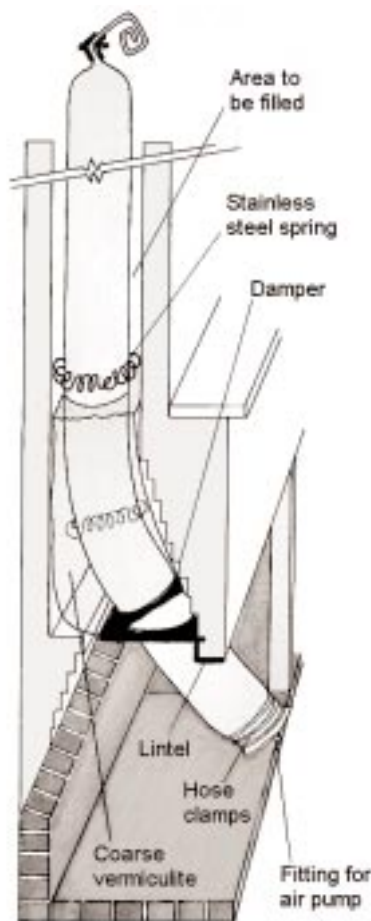

FIGURE 5

CHIMNEY RELINING

4. INSTALL AN EXTERIOR AIR SUPPLY FOR COMBUSTION AND DRAFT AIR.

Conventional fireplaces draw room air that has been heated by the home's primary heating system and exhaust it out the chimney. This air is replaced by infiltration of cold outside air through cracks and openings in the building envelope. In tightly constructed homes or homes that are already exhausting air with fans and dryers, the fireplace may be starved for air and dumping smoke into the room because of insufficient draft. A solution to these problems is to provide a means for using outside air for combustion.

There are three basic components to an exterior supply air system for a fireplace: intake, passageway, and inlet (Fig. 1). The intake is typically located on an outside wall or the back of the fireplace, but can be in a crawl space, attic, or other unheated space. Many codes will not allow location of an inlet within a garage because of the potential presence of fuel fumes. A passageway or duct connects the intake to the inlet. It is usually insulated to reduce heat loss. The inlet introduces the outside air to the firebox. A damper is necessary to control the volume and direction of air flow.

Glass doors are typically installed to prevent indoor air from entering the firebox and going up the chimney. Unfortunately, the tempered glass that is so often used is not a good transmitter of infrared radiation so the radiant heat from the fire itself is significantly reduced.

ADVANTAGES: Minimizes the exfiltration of heated conditioned-space air.

DISADVANTAGES: May be difficult to install in an existing fireplace.

5. INSTALL AN ENVIRONMENTALLY FRIENDLY GRATE.

The specially designed EcoFire Super-Grate, marketed by Andiron Technologies, can be installed to reduce the harmful emissions of a conventional fireplace. This stainless steel grate replaces the wrought-iron grate that holds wood logs. It is attached to a fan which blows air through holes in the tubes of the grate. This air results in an extremely hot fire which has lower emission levels. The heat-reflecting shield which is attached improves heating efficiency by increasing the radiant heat output.

ADVANTAGES: Easily retrofit to existing fireplaces.

DISADVANTAGES: Relatively expensive and still subject to wood-burning bans.

6. INSTALL A GAS LOG SET OR FIREPLACE.

A gas log set is primarily a decorative appliance. It includes a grate holding ceramic logs, simulated embers, a gas burner, and a variable flame controller. These sets can be installed in most existing fireplaces. There are two principal types: vented and unvented. Vented types require a chimney flue for exhausting the gases. They are only 20% to 30% efficient and most codes require that the flue be welded open, which results in an easy exfiltration path for heated room air. Unvented types operate like the burner on a gas stove and the combustion products are emitted into the room. They are more efficient because no heat is lost up the flue and most are equipped with oxygen depletion sensors, but they are banned in some states, including Massachusetts and California.

Gas fireplaces incorporate a gas log set into a complete firebox unit with a glass door (Fig. 6). Some have built-in dampers, smoke shelves, and heat circulating features that give them the capability to provide both radiant and convective heat. Units can have push-button ignition, remote control, variable heat controls, and thermostats. Gas fireplaces are more efficient than gas logs with efficiencies of 60% to 80%. Many draw combustion air in from the outside and are direct vented, eliminating the need for a chimney (Fig. 7). Some of these units are wall furnace rated.

There are also electric fireplaces which provide the ambience of a fire and, if desired, a small amount of resistance heat. These units have no venting requirements.

ADVANTAGES: No ashes or flying sparks that occur with wood-burning fireplaces. Not affected by wood burning bans imposed in some areas when air quality standards are not met. Direct-vented gas or electric models eliminate the need for a chimney.

DISADVANTAGES: Cost for equipment and running the gas line can be high. Cannot use existing masonry chimney with a gas fireplace.

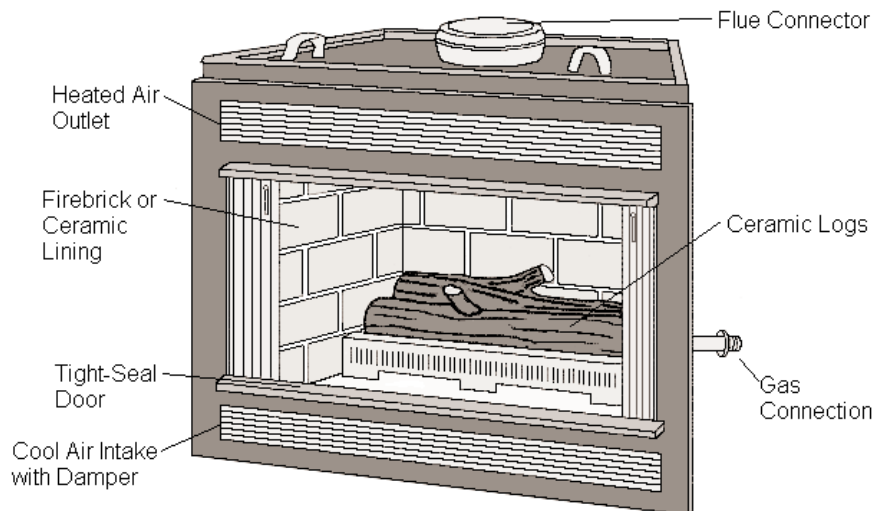

FIGURE 6

GAS FIREPLACE

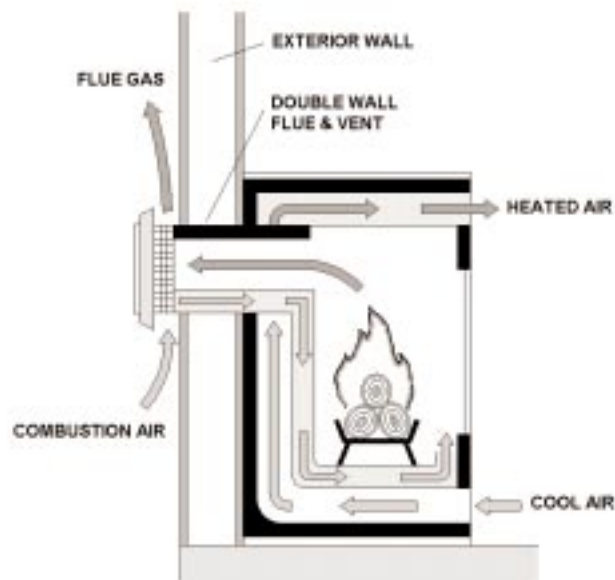

FIGURE 7

DIRECT-VENT GAS FIREPLACE

7. INSTALL A WOOD STOVE, FIREPLACE INSERT, OR ADVANCED FIREPLACE.

There are wood-burning equipment alternatives that offer an improvement over a conventional wood-burning fireplace that may only be 10% efficient. These include wood stoves, fireplace inserts, and advanced fireplace cores. The performance of wood-burning systems varies dramatically with the type of equipment, the type of wood being burned, the wood's moisture content, and the way it is maintained and operated.

Wood stoves without air controls, such as Franklin stoves, have efficiencies of 20% to 30%. Stoves with controlled air inlets into primary and secondary combustion areas can have efficiencies as high as 55%. Advanced designs can have efficiencies as high as 75%. The more efficient systems require much less excess air for combustion and produce lower levels of incomplete combustion products which produce creosote.

Wood-burning fireplace inserts are designed to fit into existing fireplaces to improve their heating performance. Some stoves sit on an existing fireplace hearth and vent up the chimney.

In response to some Western-state ordinances banning the installation of a traditional fireplace, manufacturers responded with fireplaces that meet the Environmental Protection Agency's (EPA) standards for wood stoves. These units are as efficient as the advanced wood stoves. They are air-tight with gasketed doors and a pyro-ceramic glass window that allows the infrared heat from the flame into the room. The advanced fireplace has an insulated casing to reduce heat loss through the outside wall of the house. A squirrel-cage fan is used to draw room air in and around the casing to pick up additional convective heat and supply it to the room. Heat output is controlled by the amount of outside air intake for combustion. Some even allow for short duct runs to distribute heat via natural convection to isolated rooms. RSF Energy produces a fireplace system that can supply a whole-house duct system with an in-line blower and thermostats (Fig. 8).

The Rumford-style fireplace designed by Jim Buckley is one of the only masonry fireplaces that meets most air quality standards. A fireplace kit is available for the construction of a masonry fireplace based upon the traditional Rumford design. The kit includes a one-piece curved clay throat, a clay flue tile liner, a smoke chamber, a stainless-steel damper, and optional glass doors.

ADVANTAGES: Higher efficiency than a conventional wood-burning fireplace.

DISADVANTAGES: Can be subject to wood-burning bans when local air quality standards are not met. Requires maintenance to prevent the dangerous build up of creosote.

FURTHER READING

"Back to the Future Fireplace," *This Old House*, January/February 1997, pp.74-79.

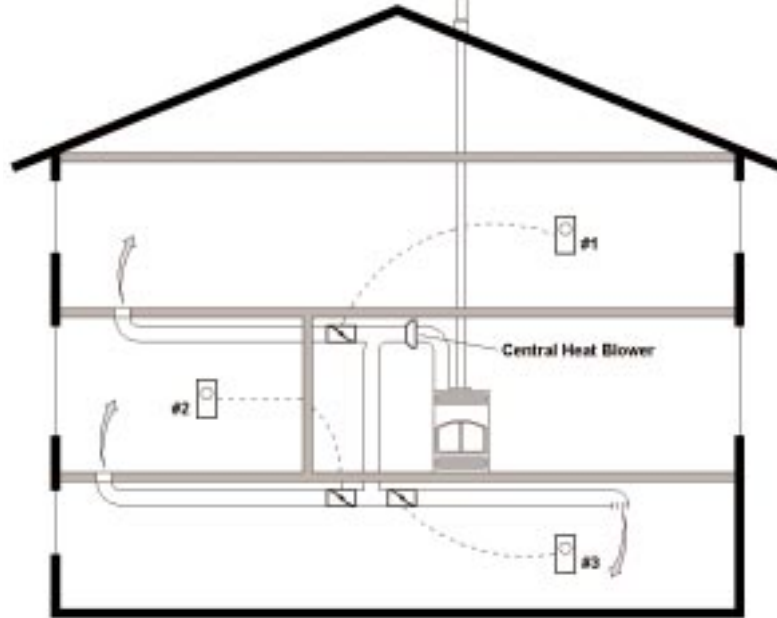

FIGURE 8

DUCTED FIREPLACE

Brick Institute of America (BIA) Technical Notes on Brick Construction. Available on-line at www.bia.org:
Technical Note 19 – Residential Fireplace Design, January 1993.

Technical Note 19A – Residential Fireplaces, Details and Construction, May 1980.

Technical Note 19B – Residential Chimneys — Design and Construction, January 1988.

Renovating Old Houses, George Nash, The Taunton Press, 1992.

Sunset Fireplaces & Wood Stoves, Lane Publishing Co., 1989.

The Fireplace Book, The Aberdeen Group, 1992.

The Old-House Journal Compendium, Clem Labine and Carolyn Flaherty, The Overlook Press, 1980.

The Stanley Complete Step-by-Step Book of Home Repair and Improvement, James A. Hufnagel, New York: Simon & Schuster, 1993.

PRODUCT INFORMATION

Andiron Technologies, Inc., 2995 Woodside Road, Suite 400, Woodside, CA; 888-4-EcoFire; www.EcoFire.com.

Buckley Rumford, 710 Foster Street, Port Townsend, WA; 800-447-7788; www.rumford.com

Heat-N-Glo Fireplace Products, 6665 West Hwy 13, Minneapolis, MN; 888-743-2887; www.heatnglo.com

Heatilator, Inc., 1915 West Saunders Street, Mt. Pleasant, IA; 319-385-9211; www.heatilator.com

Industrial Chimney Company/RSF Energy, 801 St. Nicholas, St. Jerome, Quebec, Canada; 450-565-6336; www.icc-rsf.com

Majestic Products Company, 1000 E. Market Street, Huntington, IN; 800-525-1898; www.majesticproducts.com

Temco Fireplace Products, 301 S. Perimeter Park Drive, Suite 227, Nashville, TN; 615-831-9393.

DOMESTIC HOT WATER HEATING

ESSENTIAL KNOWLEDGE

Depending on whether the home is air conditioned or not, water heating is the second or third largest energy expense in the home. Traditionally, water heating accounts for approximately 14% of the utility bill. As space heating and cooling loads decrease and system efficiencies increase, water heating represents a greater portion of the home's energy bill.

The predominant design for water heaters is the storage type (Fig.1). These units hold heated water in a thermostatically controlled storage tank. Tanks in residential applications usually have storage capacities ranging from 30 to 80 gallons. The tank may have a combustion burner in the bottom with a flue running up through the center of the tank, electric resistance heating elements immersed in the water, or a heat exchanger circulating fluid heated by another source such as a boiler.

When deciding whether or not the domestic water heating system needs rehabilitation, the following questions should be answered:

- Does the present system have several years left on its expected life?
- Is the time it takes to deliver hot water to faucets acceptable?
- Is there sufficient hot water?

In a rehabilitation situation, the answer to any of these questions could be no. Poor maintenance can shorten the life of water heaters. Bathrooms added over the years may be remote from the tank location or the addition of clothes and dish washers may have increased hot water demands beyond the original design.

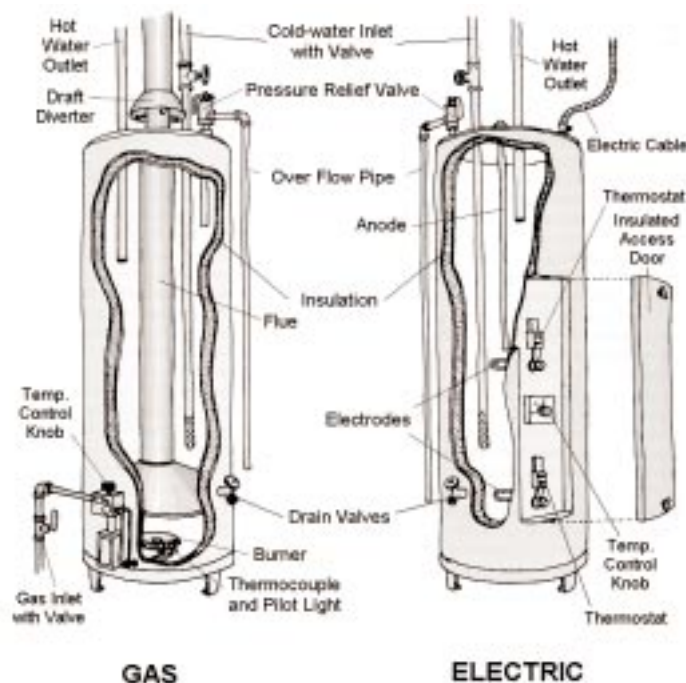

FIGURE 1

STORAGE-TYPE WATER HEATERS

The life of storage-type water heaters is typically 10 to 15 years due to the corrosion of the tank. Maintenance, such as replacing the anode and cleaning sediment from the bottom of the tank, can extend its life, but this is rarely done. Thus, if the storage tank is more than 10 years old, it should probably be replaced. The month and year that the tank was built is usually encoded in its serial number.

Demand, or instantaneous-type water heaters can be located closer to the fixture to minimize the waiting time for hot water. These units eliminate the tank and its associated losses altogether.

If purchasing a new water heater, selecting a system of the proper size and recovery rate is important to ensure that all hot water demands are met. A water heater of insufficient capacity will result in cold showers, but a water heater that is too large wastes energy. The water heater size is determined by the First Hour Rating (FHR), which is the amount of hot water (in gallons) that can be produced in one hour. The FHR is not only a function of tank size, but also recovery rate, which is a measure of how quickly the incoming cold water can be heated. Gas water heaters have higher recovery rates than electric units. Thus, for the same FHR, the gas water heater requires a smaller tank than an electric water heater.

In addition to the FHR, storage-type water heaters are given an Energy Factor (EF) rating. This is a seasonal efficiency rating that takes into account the water heater's recovery efficiency, standby losses, and energy input. Recovery efficiency is the ratio of the amount of heat that is absorbed by the water to the amount of heat input.

TECHNIQUES, MATERIALS, TOOLS

1. IMPROVE THE EFFICIENCY OF THE EXISTING STORAGE-TYPE WATER HEATER.

In lieu of purchasing a new, more-efficient water heater, there are a few relatively easy and inexpensive ways to improve the efficiency of the existing system. These are essentially the same methods that manufacturers have used to improve the efficiency of today's tank water heaters.

Insulate the tank and pipes. Older storage-type water heaters can benefit from the simple installation of an insulating jacket or blanket. This reduces the heat loss from the tank to the surrounding area. Be careful not to cover thermostats, drains, flues, or combustion air inlets. Insulating the pipes reduces the losses from the hot water as it flows through the pipes to the faucet. The split foam rubber type of insulation is effective and easy to install.

Install anti-convection valves or loops. These devices are installed on the hot water inlet and outlet pipes to prevent the convection of hot water up the pipes from the tank when in the standby mode. There are numerous types. Some are based on a simple ball-type check valve. A loop in the piping serves the same purpose (Fig. 2).

ADVANTAGES: Inexpensive and easy to do.

DISADVANTAGES: Tank blankets are not as effective as internal insulation because certain areas must be left exposed for access and venting purposes. The useful life of these measures is limited to the remaining life of the water heater. They will not be necessary for most new water heaters because high levels of internal tank insulation and anti-convection devices are standard features.

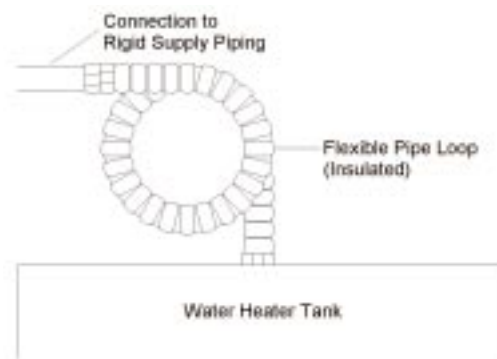

FIGURE 2

ANTI-CONVECTION LOOP

2. INSTALL AN INDIRECT STORAGE WATER HEATER.

In an older home with a hydronic heating system supplied by a boiler, a tankless coil may be the method for heating domestic hot water. This is a coil located within the boiler. There is no storage of hot water. This approach is suitable in the winter when the boiler is operating for space heating, but is inefficient in the summer because the boiler must start and stop frequently just to provide domestic hot water. An alternative is to install an indirect storage water heater (Fig. 3). Heating fluid from the boiler is circulated through a coil inside the storage tank. The boiler is still used throughout the year for domestic hot water, but it comes on less frequently in the summer because it responds to a drop in storage tank temperature and not every demand for hot water.

ADVANTAGES: Improves system efficiency.

DISADVANTAGES: Requires additional floor space for the storage tank.

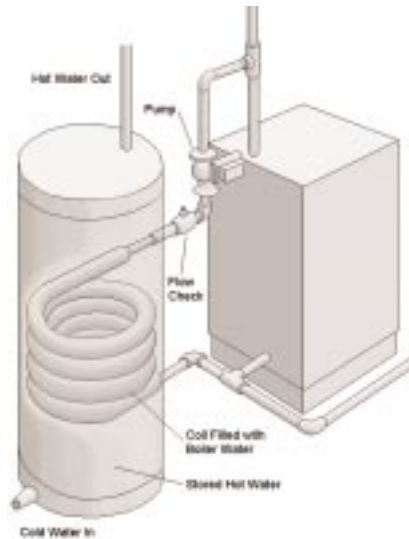

FIGURE 3

INDIRECT STORAGE WATER HEATER

3. INSTALL A NEW ELECTRIC RESISTANCE STORAGE WATER HEATER.

Although this is usually the most expensive method for heating water, it is the second most common type of water heater after gas storage units. If hot water requirements are relatively low, this may be the most practical choice. New electric storage water heaters have higher levels of insulation than the old versions. Some are all-plastic, which do not need anodes and come with lifetime, never-leak warranties. Electric storage water heaters can be located almost anywhere because there are no combustion air and venting issues. Time clocks can be used to prevent the resistance elements from operating during peak electric charge periods where time-of-use rates are in effect.

ADVANTAGES: Lower initial cost than gas storage water heaters. Installation location flexibility.

DISADVANTAGES: High operating costs.

4. INSTALL A NEW GAS STORAGE WATER HEATER.

New gas storage water heaters have better tank insulation, improved baffle designs, lower pilot burner inputs, and new combustion chamber configurations than older versions. Baffles regulate the flow of combustion air up through the flue and new designs increase the transfer of heat from the flue gases to the water, increasing system efficiency. They also reduce convective air movement and heat loss up the flue during standby periods.

As with gas furnaces, there are several venting options. Standard units are atmospheric vented

with the vertical flue that is often tied into the same chimney flue as the gas furnace. Power-vented units use a fan to assist the venting of the combustion gases. These provide more location flexibility because longer vertical or horizontal vent pipes can be used. They also cannot backdraft while the burner is operating. However, they still use indoor air for combustion and now require electricity to operate. Direct-vented units are also available that draw outside air in for combustion and vent directly out the wall.

A gas water heater that avoids the problems of venting entirely is the Seahorse by Gas-Fired Products Incorporated. This unit is a gas-fired heat exchanger with a pump that is placed in an insulated box on the outside wall of the home and plumbed into a storage tank inside the home which may be the old electric water heater (Fig.4). Going a step further is the Weather-Pro by American Water Heater. This is a gas water heater that can be installed outside, including the 50-gallon tank. Its distribution is currently limited to Southern states where freeze protection is not an issue.

ADVANTAGES: Low operating cost.

DISADVANTAGES: Higher initial cost than electric resistance storage-type water heaters. Venting requirements restrict location flexibility. Power-vented units require electricity to operate and have had occasional problems with nuisance shutdowns when their pressure safety switches have mistaken windy conditions for blocked vents.



FIGURE 4

SEAHORSE OUTSIDE GAS-FIRED WATER HEAT EXCHANGER

5. INSTALL A DEMAND WATER HEATER.

In situations where space for a 20 to 50 gallon storage tank is limited or the wait for hot water to a tap remote from the storage tank is excessive, the installation of a demand water heater may be appropriate. Also called tankless, instantaneous, and point-of-use, demand water heaters heat the water as it is called for. There is no storage tank. Some point-of-use units may not be truly instantaneous or tankless because they employ a small 2- to 4-gallon storage tank (Fig. 5).

Electric demand water heaters heat the water as it passes over a resistance element. The power requirements limit these units to water flow rates for a single sink or low-flow shower. One of the largest electric demand water heaters is the Seisco RA-28. Rated at 28 kW, it is capable of supplying 2.5 gallons per minute at a 78°F temperature rise. Electric demand water heaters typically modulate their output by using multiple heating elements. Less expensive, fixed output units do not allow for much variation in water flow.

Gas demand water heaters employ a modulating burner to supply hot water at a specific pre-set temperature. Their output is sufficient to satisfy the hot water demands of an entire home. They must be mounted on an external wall for venting purposes.

ADVANTAGES: Location flexibility due to their small size. Reduced standby losses. Longer life because the

tank corrosion issue is eliminated. When located near the point of use, they are water conserving because there is less cold water to go down the drain prior to the arrival of hot water.

DISADVANTAGES: While they can deliver hot water for an indefinite period of time, the flow rate (gallons per minute) may not be sufficient. Most units cannot serve multiple tap requirements simultaneously. Initial costs are higher than storage-type units. Require larger gas lines or power requirements than storage-type units. Service support may be less than for the more-common storage-type units.



FIGURE 5

POINT-OF-USE WATER HEATER

6. SUPPLEMENT THE WATER HEATER WITH A PREHEATING OR HEAT RECOVERY SYSTEM.

The heating requirements of the water heater can sometimes be supplemented by recovering waste heat from other processes or capturing solar energy. One of the simplest approaches is a tempering tank. This is a second uninsulated tank located in a warm or sunny area and connected in series with the primary water heater tank. Cold water first enters the tempering tank where it warms up to the surrounding air temperature. Solar water heating, both passive and active systems, can be used to preheat water and during some times of the year can meet all of the water heating needs.

Hot water desuperheaters, such as the HotTap unit by Addison Products, are hot refrigerant-to-water heat exchangers on the refrigerant line of an air conditioner or heat pump. Such a unit is installed after the compressor, but before the condenser, to remove the superheat from the refrigerant vapor and transfer it to the domestic hot water (Fig. 6). The amount of water heating provided by these systems is a function of the air conditioning usage since they only provide heat when the air conditioner or heat pump is operating.

Another method of heat recovery is the GFX (gravity film exchange). This is a heat exchanger between the water waste pipe and the DHW tank cold water inlet (Fig. 7). It consists of a section of 3" or 4" copper drainpipe with a coil of 1/2" or 3/4" tubing wrapped around it. At times of high hot water use such as showering, the water going down the drain is still hot. This device recovers some of that heat and preheats the cold water flowing into the tank. There are no controls or moving parts.

ADVANTAGES: Relatively inexpensive and require little or no maintenance. Capture heat energy that would otherwise be wasted. Desuperheaters can improve the HVAC system cooling efficiency slightly.

DISADVANTAGES: Desuperheaters only provide a benefit when the heat pump or air conditioner is operating and they can decrease the heating capacity of a heat pump system. GFX devices only recover heat when water is draining out at the same time that make-up water is flowing into the tank (e.g., water is flowing directly from the spigot or showerhead down the drain). Building codes or building officials in some areas do not allow GFX devices.

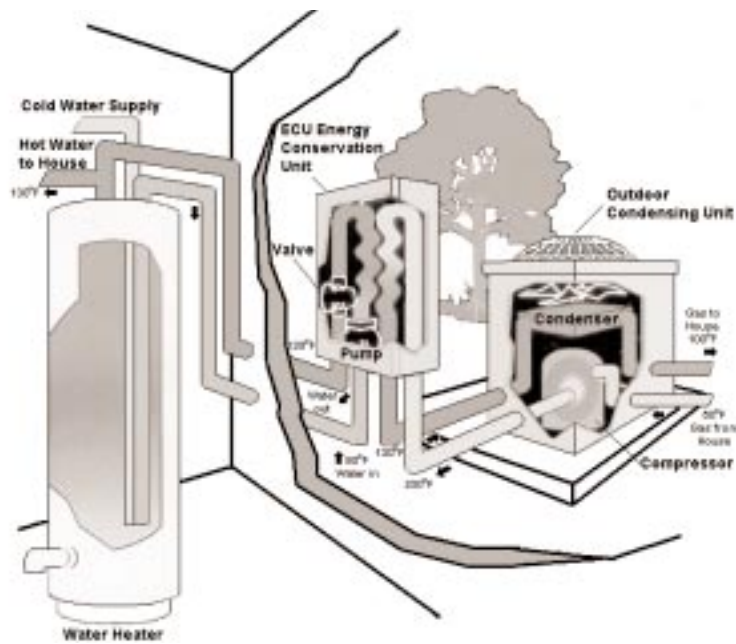

FIGURE 6

HOT WATER DESUPERHEATER

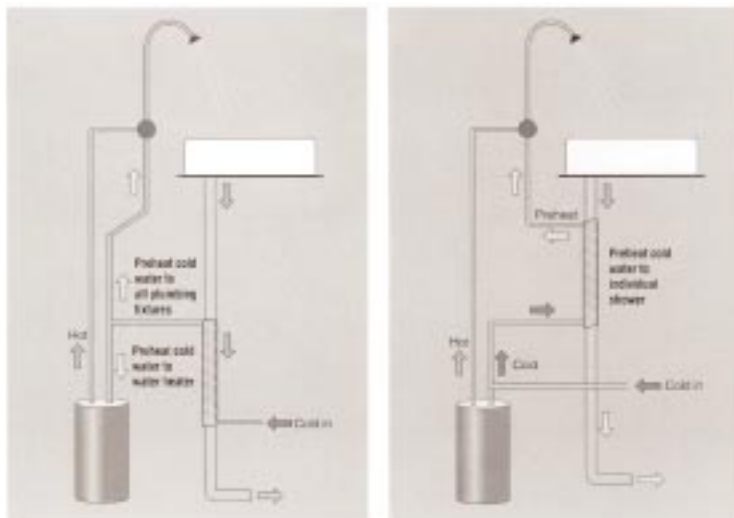

FIGURE 7

GFX HEAT RECOVERY SYSTEM

7. INSTALL A HEAT PUMP WATER HEATER (HPWH).

If electricity is the only water heating fuel alternative and the domestic hot water requirements are relatively high (e.g., four or more occupants) a heat pump water heater can be considered to reduce operating costs. It can typically provide hot water at one-half to one-third the energy use of an electric resistance water heater. Rather than heating the water directly by electric resistance, these heat pumps use electricity to drive a vapor compression cycle that moves heat from the surrounding air to the tank water. HPWHs can be integral systems with the compressor/evaporator unit sitting on top of the storage tank or as separate units requiring a pump and flow loop (Fig. 8). Integral units avoid the need for a pump and control loop but the separate unit design can be retrofitted to the home's existing tank.

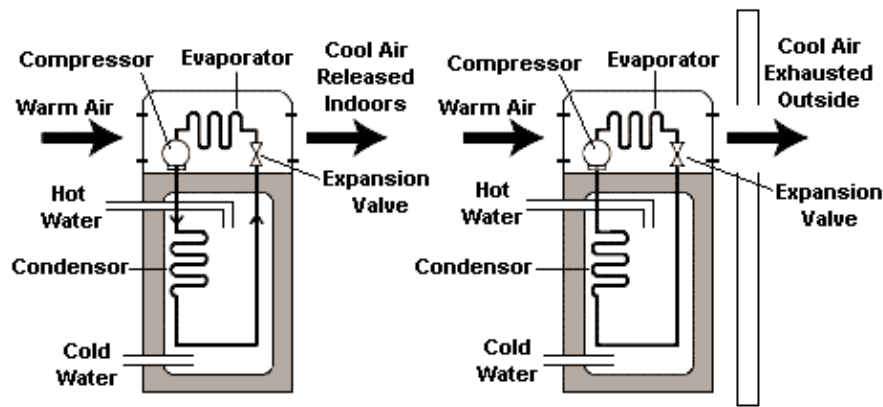

FIGURE 8

HEAT PUMP WATER HEATER

HPWHs are most appropriate in warm climates because they are typically located in basements and garages, where freeze damage is not a concern. The efficiency of the heat pump also drops at low air temperatures. HPWHs cool and dehumidify the air surrounding the evaporator section like an air conditioner. This can be beneficial in a conditioned space in the summer, but detrimental in the winter. The evaporator section cannot be in a confined space where the surrounding air is not mixed with warmer air.

HPWHs do not have the quick recovery of standard water heaters. A larger tank could be used to meet peak demands, but the more common solution is to install an electric resistance heating element in the tank to handle the peak demand periods. This defeats some of the efficiency benefits of the HPWH.

In cooler climates or where a ventilation system is employed, an exhaust air heat pump water heater (EAHPWH) may be appropriate. This system, manufactured by DEC/Therma-Stor, captures heat from the air before it is exhausted.

ADVANTAGES: Lower operating cost than an electric resistance system.

DISADVANTAGES: Higher initial cost. There are currently only a few U.S. manufacturers and there is little market infrastructure in place. Finding qualified, experienced installation and service technicians may be difficult. Their installation requires expertise in water heater service as well as refrigerant handling regulations. HPWHs need to be located where the compressor noise will not be a problem. They require regular maintenance similar to that for an air conditioner.

FURTHER READING

Residential Heat Pump Water Heaters, Federal Technology Alert, www.pnl.gov/fta/3_res.htm.

“Water Heaters and Energy Conservation — Choices, Choices!,” *Home Energy Magazine Online*, May/June 1996, www.homeenergy.org/eehem/96/9605waterheat.html.

PRODUCT INFORMATION

Addison Products Company, P.O. Box 607776, Orlando, FL; 407-292- 4400.

American Water Heater, 500 Princeton Road, P.O. Box 4056, Johnson City, TN; 800-999-9515.

DEC/Therma-Stor, P.O. Box 8050, Madison, WI 53708; 800-533-7533.

Gas-Fired Products Incorporated, Charlotte, NC; www.thermastor.com.

Water Film Energy, Inc., P.O. Box 48, Oakdale, NY 11769; 516-758-6271; www.oikos.com/gfx.

PLUMBING DESIGN & ENGINEERING

ESSENTIAL KNOWLEDGE

Properly sized and performing plumbing systems are vital for the comfort, convenience, health, and safety of home occupants. Rehabilitation reasons can range from obvious failures of a system such as leaks, corrosion, and stoppage; to not-so-obvious failures such as leaks of dangerous gas from sewers or combustion appliances. Plumbing systems can include water supply and distribution; drain, waste, and vent systems; fuel supply and storage; appliance venting and exhausting; fire protection systems; and gray water systems. Plumbing fixtures themselves are covered in another volume, as are septic systems.

There are a few major factors that drive the decision to rehab plumbing systems: how well the system meets the needs of occupants, how the system performs and complies with code requirements, how possible rehabilitation might save resources, and the cost and feasibility to rehab. The scope of rehab work can vary from simple repair, to removal and replacement of systems, to adding new ones. Fire protection systems and fuel systems are examples of added systems.

Materials, designs, and codes have changed and evolved over the years. Code-complying original installations may now be below standard or dangerous. For example, an old plumbing fixture such as a bathtub could be filled with contaminated water that could drain back into potable water supply because the fill spout is below an overflow drain. Older toilets used much more water, and older shower heads used more water and energy than those that now comply with the Energy Policy Act and the National Plumbing Standards of 1992. While “fixture” concerns are not addressed here, they drive decisions to change systems and components. Existing vents might not work with a new, more efficient appliance that produces cooler and high moisture vent products. Materials previously approved may be hazardous to occupant health or prone to failure, such as lead in water systems, which is a well publicized hazard. Certain connectors and pipe in polybutylene water systems are known to fail. Asbestos insulation in many old plumbing installations is a hazard. Recommendations regarding the removal and disposal of asbestos are available from the Environmental Protection Agency (EPA) Asbestos Information Hotline: 800-438-2474.

Designs and installations previously deemed state-of-the-art may not work well, and in some instances could be dangerous. Old drain, waste, and vent systems are examples. Without proper venting, sewer gases can create unhealthy conditions. New materials and designs can alleviate flaws. There are positive system developments as well. Research and, subsequently, codes have permitted water pipe supply sizes to be downsized for branches. The house’s present system, if in good condition, may be able to accommodate more fixtures. There are many new materials and upgrades to old materials and methods. There is a plethora of connectors, valves, reducers, and adaptors to allow change from one material to another.

As design, research, and new materials have evolved, so have codes. One national code, the International Residential Code for one- and two-family dwellings, was first promulgated in draft form and issued in 1998. It is being updated for an April 2000 release. This code covers most residential plumbing systems. The International Association of Plumbing and Mechanical Officials (IAPMO), nevertheless still publishes its “Dwelling Requirements of the Uniform Plumbing Code.”

This guide will review attributes of many systems and materials, along with advantages and disadvantages. These attributes are not necessarily comprehensive and readers are advised to undertake research of individual systems, products, installation recommendations, warranties, and code acceptance for their own locale. This guide cannot foresee the scope of a project or predict costs, but systems components are evaluated as more or less costly than others.

FURTHER READING

Plumbing a House, Peter Hemp, Newtown, CT: The Taunton Press, 1994.

Renovating Old Houses, George Nash, Newtown, CT: The Taunton Press, 1996.

The Old House Journal Guide to Restoration, Patricia Poore, New York: E.P. Dutton Books, 1992.

International Residential Code (Draft), International Code Council, Falls Church, VA 22041, 1998.

The Consumer's Guide to Home Improvement, Renovation & Repairs, The Enterprise Foundation, New York: John Wiley and Sons, 1995.

1996 ASHRAE Handbook - HVAC Systems and Equipment, ASHRAE, Atlanta, GA, 1996.

WATER SUPPLY & DISTRIBUTION SYSTEMS

ESSENTIAL KNOWLEDGE

There are many causes for rehabilitation maladies that affect water supply and distribution systems. Leaks, poor water quality, poor supply of hot or cold water, insufficient pressure, noise, vibration, and presence of hazardous materials can all be driving forces.

Water distribution in today's homes originates from a one-pipe delivery system with pipes and fittings of lead. Ancient Romans had lead water pipes, and in fact the term "plumbing" is derived from the Latin "plumbum," meaning lead. Ancient Egyptian artifacts show use of copper water piping. A variety of pipes and fittings could be present in any rehab project, including brass, copper, iron, and steel. Water piping materials and fittings have changed in popularity and code acceptance. Many types are approved for use, and can be used in combination if electrogalvanic and grounding continuity are properly addressed. Galvanized iron and galvanized steel piping (with some yellow and red brass and copper) was quite popular prior to World War II, but were replaced by copper tubing post-war and by plastics from the 1970s. Iron/steel pipes suffered corrosion and scale build-up in certain water types, especially in hot water lines. Copper tubing was approved by ASTM B88 in 1932 and is the same material used today. Copper has had some problems with aggressive, corrosive water.

There is a variety of plastic materials approved for use. Some plastic flexible water piping materials have had problems with splitting and fitting failure. One material used in the 1970s and '80s, polybutylene fittings, failed in many homes with disastrous results. A new hybrid piping material, KITEC by IPEX, is a composite pipe made of aluminum laminated between interior and exterior plastic layers. It claims national code approval, easy workability, sound dampening, and is corrosion-proof with good flow rates.

Water conservation has become mandated in recent years. Toilets, faucets, and showerheads must now often meet lower water use standards. Consumers are more cognizant of excess water use and energy cost for heating water which is wasted. Energy recovery devices are available and growing in popularity. Insulation, better system design, and solar heating options can also be explored.

Water quality and other health concerns are national and local issues. Filtering water systems are becoming more popular, installed below the kitchen sink/counter. Galvanized iron piping has corrosion problems that are often exacerbated by adverse water conditions and heat. Lead water services for houses were quite common, and lead in water continues to be a problem. Lead solder for copper joining has been banned. Jacksonville, Florida has "aggressive, corrosive water" and has banned the use of copper in domestic water systems. Asbestos was a popular insulation material for piping and must be carefully removed or encapsulated.

TECHNIQUES, MATERIALS, TOOLS

The water system should be thoroughly inspected and tested. Depending on the reason for rehabilitation, the water distribution system can be repaired, modified, or replaced. Some reasons include presence of

lead piping, failed polybutylene joints or pipes, low water pressure, corroded or broken pipes in under-slab or concealed locations, or condensation on cold water piping due to deteriorated or missing insulation. Codes may require renovations to any plumbing system to conform to current code without requiring the entire system to comply. Failed systems can be ripped out and replaced entirely or in part with the same or differing materials. Many adapters and couplings are available for these purposes. Note that water distribution systems have historically been used for grounding electrical systems. Please keep this in mind during rehab work and restore or provide for this important safety requirement.

Design requirements for water distribution systems are water volume, water pressure, number of fixture units, the total water demand, the height of fixtures above the water supply (static head), frictional loss due to distance and piping material, and the developed length of the pipe and fittings. Code requirements may vary from one municipality to another, but water supply fixture limits and minimum branch sizes are mostly the same. These are some code requirements to satisfy proper system performance: minimum (15 psi) at the highest plumbing fixture, and maximum (80 psi) system pressures are required for the water source. Tanks and pumps increase pressure and pressure regulators and relief or vacuum valves decrease pressure. Piping design for single-family houses is usually done by a plumber with approval by the plumbing inspector. Professional engineers typically are never involved with single-family plumbing systems. A good guide to design is by plumber Peter Hemp in *Plumbing a House*.

1. IMPROVE WATER DISTRIBUTION.

Water distribution systems and house sizes have changed over the years from small homes with limited systems to large ones with elaborate systems. Long delays for hot water at remote fixtures created a shift from single-pipe systems and introduced recirculating hot water systems. These loop systems can be expensive and use large amounts of energy in water heating and pumping if not properly designed. The draining of cold water awaiting hot water in the single-pipe system is resource depleting and time consuming. NIBCO has a “Just Right” modified loop product that uses natural convection to circulate hot water. A check valve and passive recirculating line forming the “forgotten” system can be easily installed for a similar passive recirculation system. The electric tracer wire system has a single pipe hot water self-regulating supply system that solves many loop problems. MetLund D’Mand System is suitable for rehabilitation and adaptation to existing plumbing. A remote sink has a pump and control system installed on the fixture angle stops. A push-button calls for hot water and the pump recirculates the water, which saves energy and water (Fig. 1).

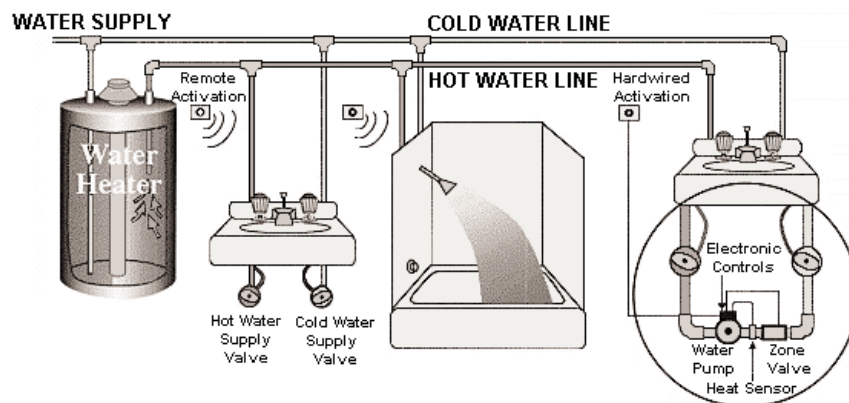

FIGURE 1

METLUND D'MAND RECIRCULATION SYSTEM

Manifold distribution systems are now recognized by major codes. The introduction of flexible plastic tubing like PEX-cross-linked polyethylene allows easy distribution of small-diameter, joint-free branches to individual fixtures. A larger supply line is connected to the manifold. The systems claim faster hot water delivery, balanced flow, easily accessible control valves, and no water hammer. This is an appropriate solution that can be installed around an existing failed system, with phased replacement of fixtures and branches. A classic distribution concern is water leaks and resultant damage. Aqua-Stop offers a water leak detection system (Fig. 2). Sensors are placed on the floor near potential leak sources, such as toilets, tubs, dishwashers, water heaters. The sensors will shut the main supply valve if a leak occurs and sound an alarm. System sensors can be hard-wired or remote.

ADVANTAGES: Improves responsiveness of water distribution throughout the home.

DISADVANTAGES: Some systems can be costly. Consult local codes as to whether such systems are permitted.

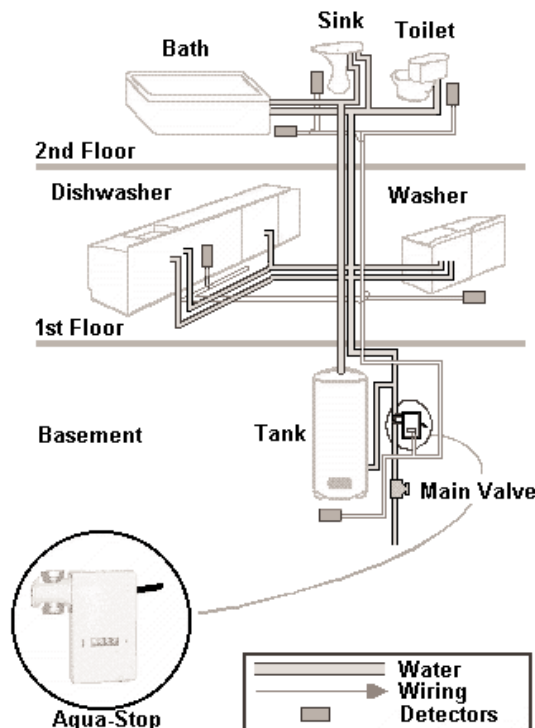

AQUA-STOP INSTALLATION

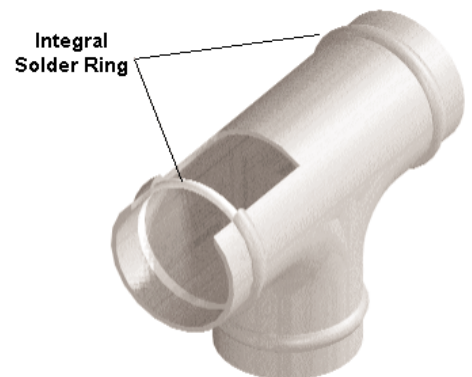

INTEGRAL SOLDERING FITTING

FIGURE 2, 3

2. INSTALL NEW COPPER PIPING.

Copper is a very popular material used since the 1930s. Joint solders previously contained some percentage of lead. Federal law changed to prohibit lead solder in potable water systems. Joints are made by soldering, brazing, and two-component adhesives. Soldering can be done by electric resistance tools and by torches. Tees can now be mechanically pulled from continuous tubing with new tools. A “new” copper fitting has recently been introduced from Europe: patented in 1934, the “integral soldering” fitting has been a standard in England (Fig. 3). IMI Yorkshire now imports American-sized integral soldering fittings, which ensure the proper amount of solder is provided. The solder is in the middle of the fitting, which provides a better joint and saves labor. Copper tubing is inserted into each end of a fitting, applied heat melts the solder ring, and the two tubes are fused together.

ADVANTAGES: Nearly every code approves; long track record; relatively easy installation; limited 50-year warranty; corrosion resistant with some water types; less support needed than plastic pipe; fire resistant; comes in coils and tubes.

DISADVANTAGES: Higher cost; some aggressive water attacks copper; flame normally present in joining; system noise; conducts heat and needs insulation; condensation concerns; tubing can kink.

3. INSTALL CHLORINATED POLYVINYL CHLORIDE (CPVC) PIPING.

Used since the 1950s, CPVC is approved by most codes for both hot and cold water distribution. BF Goodrich, inventor of CPVC, reformulated it in 1992 to be more workable in cold weather—an earlier drawback. CPVC is popular in new construction applications above and below slabs.

ADVANTAGES: Lower cost; easy installation and joining; no corrosion concerns; no water hammer; reduced conductance losses, which saves energy and reduces condensation; comes in coils and tubes.

DISADVANTAGES: More support needed than copper or steel; 24-hour joint cure time recommended; needs expansion capacity for piping by all codes; relatively recent product (first used in 1959). Installation during extremely hot temperatures can result in later joint failure.

4. INSTALL CROSS-LINKED POLYETHYLENE (PEX) PIPING.

Cross-linked polyethylene (PEX) flexible thin wall tubing had its beginnings in Europe in the 1970s and has been in use the U.S. since the 1980s for radiant heating systems and hot and cold water distribution systems. Most codes approve its use, and some allow 3/8" branches. Long PEX coils are used in the new manifold water distribution systems, and eliminate expensive joints.

ADVANTAGES: Low cost; relatively easy installation. Highly flexible; greater water flow; joints and repairs can be made wet; tubing has memory, returns to old shape; kinks can be removed by heat; eliminates water hammer; improved freeze-resistance with better insulation than metallic piping; easy repair. Seems less vulnerable to nail punctures.

DISADVANTAGES: Not all codes approve; should not be exposed to sunlight; needs room for expansion; more support required than copper or steel.

FURTHER READING

1996 ASHRAE Handbook - HVAC Systems and Equipment, ASHRAE, Atlanta, GA, 1996.

Plumbing a House, Peter Hemp, Newtown, CT: The Taunton Press, 1994.

Renovating Old Houses, George Nash, Newtown, CT: The Taunton Press, 1996.

The Old House Journal Guide to Restoration, Patricia Poore, New York: E.P. Dutton Books, 1992.

Journal of Light Construction, March 1997.

"The Forgotten Hot Water Recirculating System," *PM Engineer*, May 1998.

PRODUCT INFORMATION

BF Goodrich, Flow Guard Gold (CPVC), Cleveland, OH 44141; 800-864-4851; www.flowguardgold.com.

Copper Development Association, New York, NY; 800-CDA-DATA; www.copper.org.

Yorkshire Fittings, USA, Brentwood, TN 37027; 615-309-8669.

IPEX, Inc. (KITEC), Englewood, CO 80112; 800-473-9808; www.ipexinc.com.

Metlund, Costa Mesa, CA; 800-METLUND; www.metlund.com

NIBCO "Just Right," Elkhart, IN 46516; 800-234-0227; www.nibco.com.

SPARCO Anti-Scald Valve, Warwick, RI 02886; 401-738-4290; www.sparco-inc.com.

US Brass, Brass PEX, Dallas, TX; 800-872-7277; www.usbrass@zurn.com.

DRAIN, WASTE, & VENT SYSTEMS

ESSENTIAL KNOWLEDGE

There are a number of indications of the need to rehabilitate the drain, waste, and vent systems: leaks; clogged, slow, or non-working drains; or odors. The nature of these problems can be complex, so thorough investigation is advised. Leaks and slow drainage may reveal corrosion in waste pipes. Previous rehabs might have introduced dissimilar materials that corrode through electrogalvanic action, e.g., brass and iron fittings joined. Drains need to be sloped to remove waste water and solids. Building or pipe settlement can change pipe slope and the system may not work properly or may fail entirely. Odors can be a warning of serious problems. A toxic, explosive blend of gases could be present, caused by something as simple as a dry trap or as serious as a non-existent vent system. Vents protect against back pressure and siphoning and provide system air circulation. Cross connections are also a concern. Waste system design has evolved over time, and older approved methods did not recognize that siphoning could occur between potable and contaminated water. Older tub installations are an example with supply being located below overflow drains (Fig. 1). Local codes should be checked before proceeding with rehabilitation.

Drainage systems are basically gravity designed with venting introduced to assure the system performs properly. System capacities are now better understood, and codes allow smaller pipes. The older, existing system to be rehabed may potentially allow for greater expansion. The National Plumbing Standards was adopted in 1992 to mandate water-saving toilets, shower heads, and faucets. New materials, methods, and devices are now used along with old standards. Cast iron piping in a bell and spigot configuration was a common material, and has been replaced since the 1970s by plastics. Now hubless cast iron is regaining some upscale market share due to its sound-dampening properties.

Depending on the reason for rehabilitation, systems can be repaired, modified, or replaced. Proper analysis of the existing system and its condition is crucial. Various non-destructive diagnostic tools

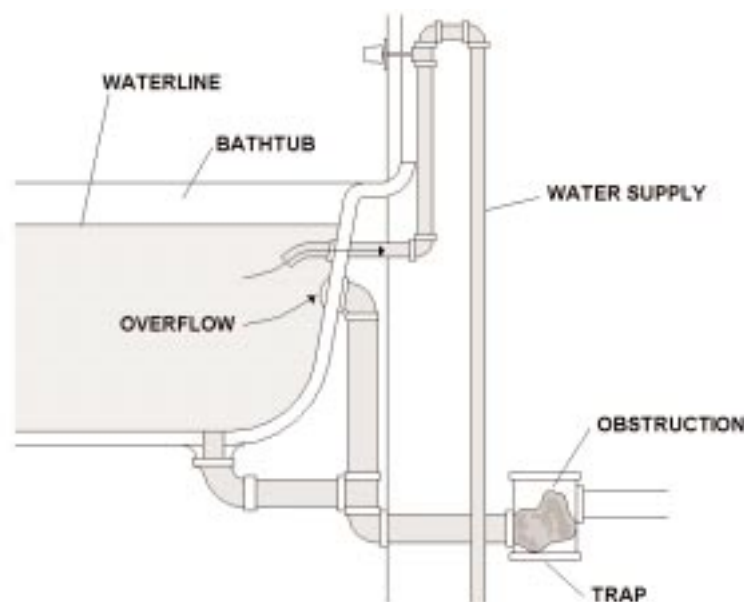

FIGURE 1

POTABLE WATER CONTAMINATION

and services are available if opening up walls or ceilings or access under slabs for inspection is not an option. Small pipe TV inspection and electronic leak detection systems are examples.

Drainage system materials used in residential construction include cast iron, galvanized and non-galvanized steel, galvanized wrought iron, lead, copper, brass, vitrified clay pipe, and plastics—acrylonitrile butadiene styrene (ABS-DWV) and polyvinyl chloride (PVC-DWV). Rehab projects on houses built after 1970 might involve plastic DWV pipe and fittings. Adapter fittings allow use of a variety of materials if desired. Cast iron is a better sound insulator but more costly, so blended systems are popular. Cast iron is used in sound-sensitive areas and plastic in non-sensitive areas. Existing materials can be combined with new or other materials, provided electrogalvanic or code concerns are addressed.

There are many new code-approved drainage systems and designs that can be considered. If the system is to be modified or replaced, a new design could be in order. New designs might be adapted to solve problems with the existing system. Drainage systems are calculated to handle a certain load, and fixtures are assigned values known as fixture units. These units are added to determine pipe sizes. Code tables state maximum unit capacity and lengths for drains and vents, and minimum pipe sizes. Local codes should be consulted.

Vent strategies have evolved from conventional to common vent, wet venting, waste stack venting, and circuit venting. Various strategies evolved to minimize pipe runs and roof penetrations. A common vent connects two fixtures. The wet vent pipe doubles as a waste pipe and is increased in size. Wet vents may be horizontal (Fig. 2), vertical (Fig. 3), or combined (Fig. 4). Waste stack venting requires all fixture drains to connect separately to it (Fig. 5). Size requirements apply to these alternate methods. Circuit venting can connect a maximum of eight fixtures to a horizontal drain (Fig. 6). Slope and size requirements apply here as well. In cold regions, vents penetrating roofs may experience frost or snow closure; a pipe at least 3" in diameter is required for the last portion of the vent.

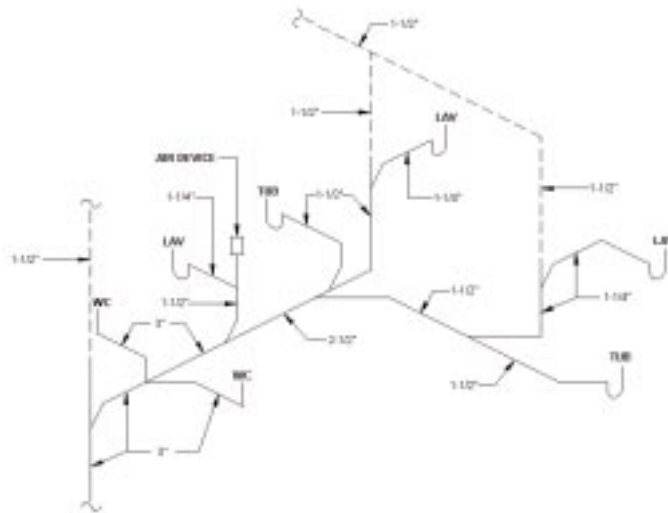

FIGURE 2 TYPICAL HORIZONTAL WET VENTING

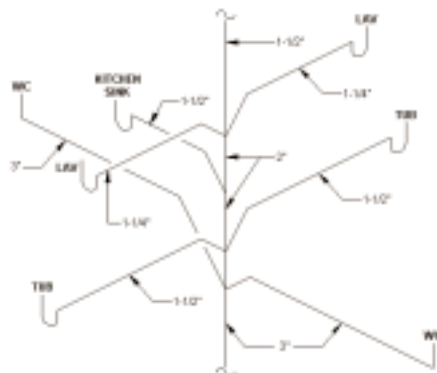

FIGURE 3 VERTICAL WET VENTING

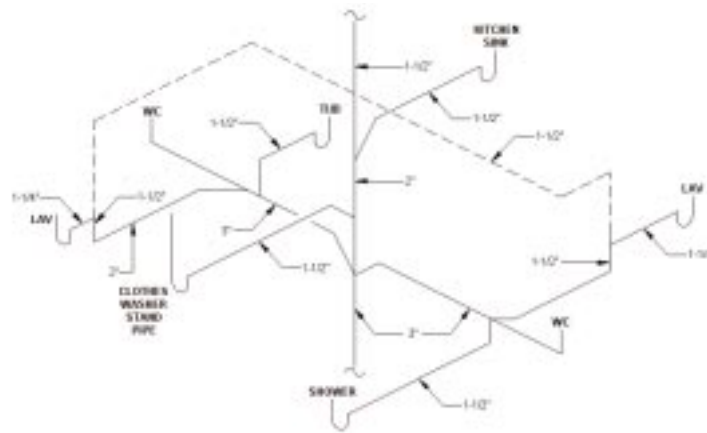

FIGURE 4

COMBINATION VERTICAL AND HORIZONTAL WET VENTING

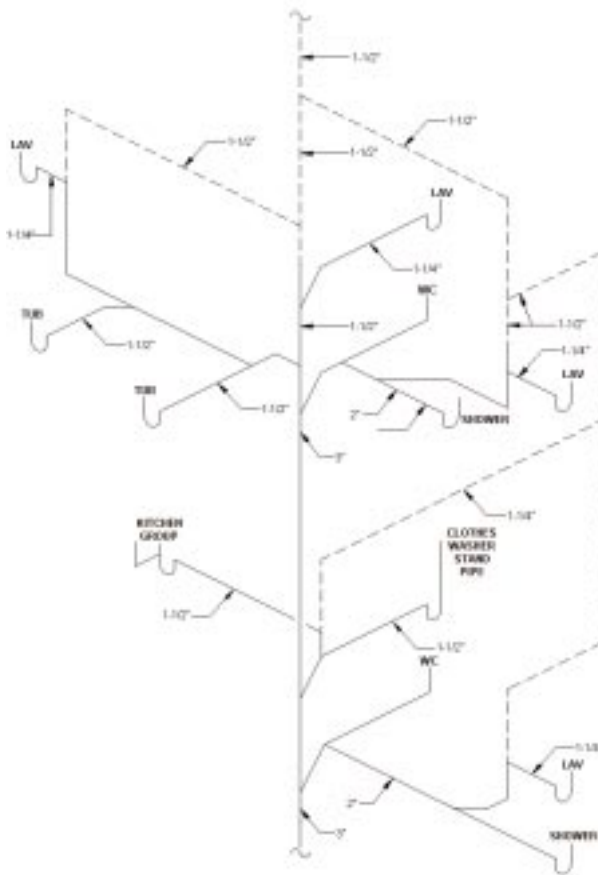

FIGURE 5

TYPICAL SINGLE-STACK SYSTEM FOR A TWO-STORY DWELLING

TECHNIQUES, MATERIALS, TOOLS

1. INSTALL CAST IRON DRAIN, WASTE, AND VENT (DWV) PIPING.

Cast iron was originally used in bell and spigot configurations with lead and oakum joints and upgraded to Tyler or rubber compression joints. Hubless pipe and fittings joined with elastomeric and stainless steel couplings are most popular currently. Cast iron can rust and is coated with an asphaltic compound. It almost disappeared as a residential waste pipe material in the 1970s, but is still used.

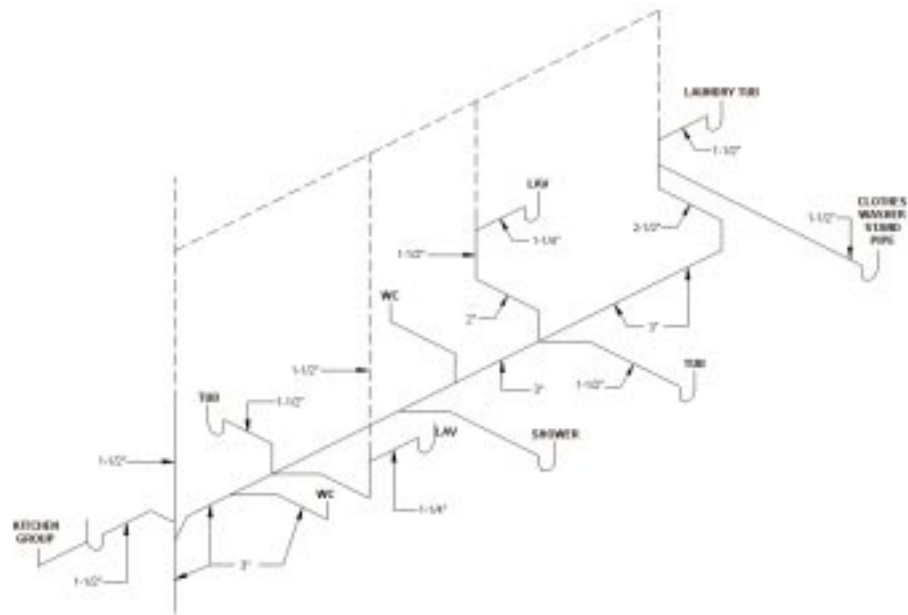

FIGURE 6

CIRCUIT VENT WITH ADDITIONAL NON-CIRCUIT VENTED FIXTURES

ADVANTAGES: All codes accept. Fireproof, good sound insulator; stronger, requires less support; long lasting; can be buried in a trench; needs no protection from nail punctures; 3" pipe fits in standard 2x4 wall without furring; needs no expansion allowance; hubless is easy to disassemble.

DISADVANTAGES: High cost and weight; requires more labor to install; not easy to cut.

2. INSTALL COPPER DWV PIPING.

Copper DWV is found in many older systems. It is also more costly than cast iron. The torch needed for joining copper creates a potential fire hazard, but new joining techniques are available. For example, an electric resistance joint tool can be used; Copperbond, is a UL-approved two-component adhesive that replaces soldering or brazing.

ADVANTAGES: Accepted by all codes; thin wall, lightweight, easy to cut and assemble; 3" pipe/fittings fit in 2x4 wall; fireproof; less labor than cast iron.

DISADVANTAGES: Costs more than cast iron; transmits noise but not as much as plastic does; requires nail protection plates; open flame typically required for joints.

3. INSTALL ACRYLONITRILE BUTADIENE STYRENE (ABS-DWV) AND POLYVINYL CHLORIDE (PVC-DWV) PIPING.

Plastics—ABS-DWV and PVC-DWV—are the predominant materials now used in rehab and new residential construction. In various regions of the country, plumbing professionals seem to have preferences for one material over the other—typically the materials do not share a given market equally. Reduced cost and labor are reasons for popularity. Most codes accept these materials. New York State code will not allow plastic in underground residential use.

ADVANTAGES: Low cost; less labor intensive; easy to cut and assemble; lightweight.

DISADVANTAGES: Fumes present with solvents and primers; material transmits noise; expands slightly; needs more support; care needed with underground installation; protection needed for nail punctures; ABS burns on its own, while PVC burns only with flame present; ABS deteriorates in sunlight.

4. INSTALL PUMPS AND EJECTORS TO DISCHARGE WASTE.

Slow or stopped waste drains may indicate that the drainage connections do not meet gravity requirements in rehab situations. Adding a pump might solve marginal or non-performing lines. Also, new plumbing fixtures might be located so that gravity will not expel waste (ie: basement fixtures). Sewage ejectors,

pumps, or grinder pumps may be required to lift discharge. Specific code requirements exist on pipe sizing, venting, electrical connections, and audiovisual alarms. These devices should only be used when absolutely necessary because of cost, access requirements, pump failure, and power failures. The units must be well sealed and designed for removal and replacement. Check with local authority on placement; exterior locations are typically most desirable.

ADVANTAGES: Allows plumbing fixtures below gravity connection points.

DISADVANTAGES: Costly; power failures stop system; needs a monitoring system and alarm; easy access required for unit replacement.

5. INSTALL GRAY WATER AND HEAT RECOVERY DEVICES.

Rehabilitation requires consideration for resource savings alternatives. Low-flow fixtures and shower heads to save water and energy are now mandated by the Energy Policy Act. Gray water collection systems are a sustainable choice for any rehab project because they recycle water from bath tubs, showers, lavatories, and clothes washing machines. The Uniform Plumbing Code allows gray water to be collected and used for irrigation. As a conservation method or in areas with restricted water use, gray water systems may be appropriate. However, cross-contamination is a concern with gray water. Check your local code for design requirements and approval. Heat recovery devices for waste hot water are new, energy-saving options. One waste water heat recovery device is the GFX. Shower, laundry, bath, dishwasher, and sink waste hot water flows through a copper DWV section wrapped with a copper water pipe feeding the water heater (Fig. 7). The device is installed vertically in the main drain and works best in basement applications, but non-basement applications are available. Most codes approve its use.

ADVANTAGES: Saves resources; gray water allows landscape gardens in arid locations; GFX saves energy.

DISADVANTAGES: Costly; cross-contamination concerns; needs storage containers; GFX needs basement location for best results; may be difficult to obtain.



FIGURE 7

GFX WASTEWATER HEAT RECOVERY SYSTEM

6. INSTALL AN AIR ADMITTANCE VALVE.

An air admittance valve is a relatively new device approved by some codes that can aid plumbing rehab. Some plumbing fixtures are difficult to vent due to location—kitchen island sinks are the classic example. An air admittance valve placed above the trap eliminates all other vent piping (in some circumstances; generally, at least one vent in the system is required to terminate above the roof line). Studor Inc. invented the technology and such vents are popular in Europe. Air admittance valves allow air to enter but prevent gases from escaping (Fig. 8). Valves must be accessible and installed above the fixture served (Fig. 9).

ADVANTAGES: Allows venting in difficult locations; saves venting pipe and materials.

DISADVANTAGES: Less costly, spring-activated devices were used in manufactured homes and spring corrosion caused a high failure rate. Diaphragm designs of Studor and others do not have the corrosion problem. Not all codes allow air admittance valves.

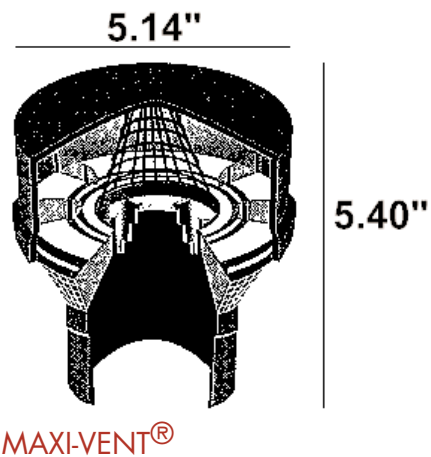

FIGURE 8



FIGURE 9

AIR ADMITTANCE VALVE BEHIND SINK

FURTHER READING

- Directory of Water Conserving Plumbing Products*, Walnut, CA: IAPMO, updated monthly; 909-595-8449.
- 1997 Dwelling Requirements of the Uniform Plumbing Code*, Walnut, CA: IAPMO; 909-595-8449.
- International Residential Code (Draft)*, International Code Council, Falls Church, VA, 1998.
- The Old House Journal Guide to Restoration*, Patricia Poore, New York: E.P. Dutton Books, 1992.
- Plumbing a House*, Peter Hemp, Newtown, CT: The Taunton Press, 1994.
- The Consumer's Guide to Home Improvement, Renovation & Repairs*, The Enterprise Foundation, New York: John Wiley and Sons, 1995.

PRODUCT INFORMATION

- Cast Iron Soil Pipe Institute, Chattanooga, TN 37421; 423-892-0137; www.cispi.org.
- Charlotte Pipe & Foundry (cast iron), Charlotte, NC 28235; 800-438-6091; www.charlottepipe.com.
- Studor, Inc. Air Admittance Valves, Dunedin, FL 34698; 800-447-4721, www.studor.com.
- WaterFilm Energy, Inc., P.O. Box 48, Oakdale, NY 11769; 516-758-6271; www.oikos.com/gfx.

FUEL SUPPLY SYSTEMS

ESSENTIAL KNOWLEDGE

There are three predominant residential fuel systems—natural gas, propane, and fuel oil. Rehabilitation might be necessary in the event of leaks, odors, corrosion, system damage, or appliance change. Gas—manufactured from coal or derived naturally from underground sources—has been used in houses since the mid-1880s. Lighting and cooking were first uses of gas with space and water heating added later. Propane (liquified petroleum gas) became a residential fuel source in the 1920s and has approximately 5 million residential customers currently. Oil became a source in the same period but the 22,000 houses built in Levittown, New York starting in 1947 gave oil a big boost. There were 16 million residential customers pre-oil embargo (1973), 12 million thereafter.

As with any plumbing system, the existing condition and code compliance should be determined. Natural gas system designs depend upon utility supply pressure, heating value of the gas, appliance needs, and distances from supply to appliances. Negotiating a higher service pressure from the utility allows for a smaller internal distribution system. The gas load center concept is a relatively new fuel system innovation. The concept is similar to electrical distribution with a central panel and branch circuits. Gas lines come to a manifold at a panel and valved branch runs connect to gas appliances. Flexible gas tubing with fewer joints allows the concept to work easily. In some homes in Japan portable cooking appliances and ventless portable space heaters are plugged into quick-connect gas outlets. The trend is likely to grow here as well. MB Sturgis makes quick-connect gas outlets for barbeques and other appliances. Another trend concerns seismic safety; Los Angeles now requires seismic activity-triggered shutoff valves for gas systems in new homes. Flexible gas tubing, now available, may be a safe alternative because it is less likely to shear or rupture between joints.

Propane and oil systems usually have a fuel delivery source that provides service as well. System designs are per local and national codes. These two fuels require a storage tank in addition to the delivery source. The propane tank is owned by the service provider and must be outside the residence. Tanks can be below grade, but typically are above. Ten feet from the house exterior is a typical distance for tank location, but they can be closer. Underground connections are typical, with polybutylene frequently used as a new underground material for piping.

Oil storage tanks can be indoors or outdoors. Existing underground tanks should be surveyed for corrosion—a major problem, with potential environmental impacts due to leaks. Indoor tanks require venting and a blocked vent line causes filling problems. Oil systems may have a single supply pipe or a loop.

Carbon monoxide (CO) from fuel combustion is a safety concern and certain manufacturers and associations recommend installing sensors near potential CO sources. Some first-generation carbon monoxide detectors were too sensitive and alarmed at non-dangerous levels. New detectors are available now with appropriate alarm thresholds.

TECHNIQUES, MATERIALS, TOOLS

The following are the most common fuel supply system piping and fittings. Consult your local code agency, utility, or supplier for other materials and methods.

1. INSTALL STEEL PIPE AND FITTINGS.

This is the traditional material for residential fuel systems, along with cast iron pipe. The majority of systems use threaded joints but welded joints are also common in older homes (which may make systems rehab more complicated). It is the most popular natural gas piping material in new construction. The rigid nature of steel pipe might make rehab projects difficult. Flexible tubing, if allowed by your local code, usually is easier for installation in rehab work.

ADVANTAGES: All codes approve; low material cost; requires fewer supports; nail proof.

DISADVANTAGES: Labor-intensive; sophisticated tools required; rigid; difficult to modify; heavy; can corrode; pipe should not be used for support when exposed (clothes racks, etc.) because of pipe damage/breakage.

2. INSTALL COPPER PIPE AND FITTINGS.

This is the traditional material used today in residential propane and fuel oil installations. It is allowed by some utilities and codes for natural gas fuel supply and is painted yellow to distinguish it from water piping. Sulphur found in some gas corrodes copper and internal tinning is required in the tubing. See Section 12 for connection techniques.

ADVANTAGES: Approved by most codes; flexible; faster; easier to install; allows long runs; fewer fittings; lightweight; corrosion-resistant; easy to modify; easy for manifold systems; easy appliance hookup.

DISADVANTAGES: Not allowed by some utilities for natural gas; can be easily confused with water piping; some gas is corrosive to copper; needs nail plates to prevent puncture; needs more pipe supports than steel.

3. INSTALL CORRUGATED STAINLESS-STEEL TUBING (CSST).

Developed initially in Japan, CSST was first manufactured in the U.S. in 1988. It is now approved by most major codes. CSST is used in residential and commercial work with natural gas and propane. It is gaining market acceptance, with five U.S. manufacturers now producing CSST. Features mechanical couplings that vary per manufacturer. Plumbers require training before installations. Widely used in manifold distribution systems.

ADVANTAGES: Wide code approval; flexible; lightweight; faster and easier to install; long runs with fewer fittings; easy to modify; one-person installation; corrosion proof; easy for use with manifold systems; easier appliance hookup.

DISADVANTAGES: New material; still not approved by some codes; higher material cost; requires specialized tools for assembly; needs nail plates to stop punctures; needs more support than steel.

FURTHER READING

1996 ASHRAE Handbook - HVAC Systems and Equipment, ASHRAE, Atlanta, GA, 1996.

Domestic Oil Burners, Charles A. Burkhardt, New York: McGraw-Hill, 1961.

National Fuel Gas Code (NFPA 54), International Approval Services, Cleveland, OH 44131, 1996, www.gasweb.org/gasweb.

PRODUCT INFORMATION

Copper tube, Copper Development Association, New York, NY; 800-CDA-DATA; www.copper.org.

Gas Tite, TiteFlex Corporation (CSST), P.O. Box 90054, Springfield, MA 01139; 800-662-0208; www.tite.flex.

P.G.P., Parker Hannifin Corp., Paraflex Division, Ravenna, OH 44266; 800-4-PARFLEX, www.parker.com/fcg.

TracPipe, OmegaFlex, Exton, PA 19341, 800-671-8622, www.omegaflex.com.

WARDFLEX Ward Manufacturing, Blossburg, PA 16912; 800-248-1027; www.wardmfg.com.

APPLIANCE VENTS & EXHAUSTS

ESSENTIAL KNOWLEDGE

Combustion appliances require venting and certain appliances require exhausting. Rehab work on vents and exhausts may be needed because of failure of equipment, venting, or structure. Venting failures may be deadly or cause health problems, and are difficult to ascertain. Carbon monoxide deaths are often in the news and detectors are becoming more common. Venting failure indicators might include corrosion, smoke (with oil equipment), soot, backdrafting, appliance operation failure, excess moisture, or visual damage.

Combustion appliances can be fueled by natural gas, propane (liquified petroleum gas), or oil. Traditionally, appliances were designed with a draft hood or diverter to vent combustion gases. Vents were sized based on tables indicating maximum capacities for certain vent area, height, lateral (horizontal run), and material. Traditional venting materials are masonry (lined and unlined), cement asbestos pipe, and single- and multi-walled metal pipe.

The 1987 U.S. National Appliance Energy Conservation Act (NAECA) increased minimum efficiency requirements for residential gas and oil-fired appliances, because vents will not perform properly if they are too large or too small. The annual fuel utilization efficiency (AFUE) became at least 78% for gas appliances and 80% for oil. New appliances meeting these and higher AFUE ratings produce fewer and cooler combustion products. Condensation and corrosion can be a problem because moisture can deteriorate chimneys through freeze/thaw action and corrode metal vents. New high-efficiency, self-condensing appliances produce such cool, moist exhaust that they use venting materials similar to drain system materials and need to be sloped to drain the moisture.

In response to higher efficiency appliances, the National Fuel Gas Code (NFPA 54) in 1992 changed venting design requirements with concern for minimum and maximum flue capacities. Certain fan-assisted combustion system appliances were included to overcome venting problems. Oil appliance venting design standards have never been published but are expected in NFPA Standard 31.

Some non-combustion appliances require exhausts. Codes require clothes dryer exhausts, and gas ranges should be exhausted (but are not required to be). Dryer failure indicators may be excess moisture, clothes not drying, high energy bills, smoke, or odors. Lint and grease buildup can create fire hazards, while blocked systems or combustion by-products can create health hazards.

The physical condition of the existing venting and exhaust system should be checked, especially to insure the passageway is properly lined, clear, and free of obstructions. If the vent/chimney was previously used for solid or liquid fuel, it should be cleaned. The failure indicators mentioned above need to be reviewed and system operation verified. Ages of combustion appliances should be matched to the vent system to determine if a new efficient appliance has been installed without an appropriate flue modification. As mentioned above, improper venting and flue damage may result. Existing oil appliances might have had their older burners replaced with the more efficient retention-head oil burner. This could require a flue modification because new levels of water and acid concentration could be present. Typically corrosion-resistant materials and/or heat loss reduction are introduced to ensure proper draft and reduce condensation. Some codes require the existing chimney or vent be brought into code conformance if a new appliance is connected.

A properly designed vent controls draft and removes flue gases. Selection of a replacement vent or checking compliance should consider factors such as appliance draft, configuration, size, heat, and

condition; construction of surroundings; building height; material selection; and code requirements. Charts in codes show selection, clearance from combustible material, and vent termination requirements. Gas appliances are classified in four categories that allow different listed vent products. Category I has non-positive vent static pressure with vent gas temperature that avoids excessive condensation production in the vent. A Type B vent is listed and labeled for this category. Other categories require special vents. Additional requirements exist for multiple appliance vents. Direct-vented appliances have through-wall designs. To ensure intake air and combustion gas outlets are in proper locations, one guide is shown (Fig. 1).

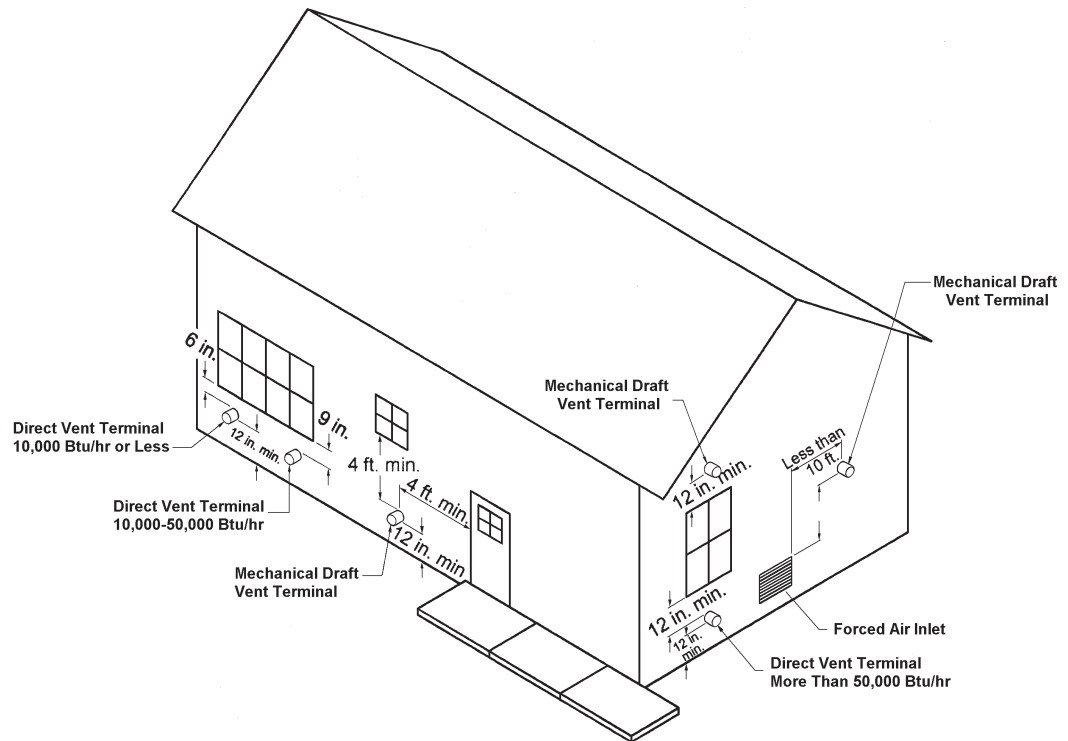

FIGURE 1

THROUGH-WALL VENT LOCATIONS

TECHNIQUES, MATERIALS, TOOLS

1. INSTALL A NEW EXHAUST FOR A CLOTHES DRYER.

Installing a new clothes dryer or modifying an existing dryer installation may be part of the rehab project. These appliances, whether gas or electric, require exhausting to the home's exterior. Lint buildup may lead to fire or health problems, making exhausting imperative. The International Residential Code for One and Two Family Dwellings (IRC) has specific requirements for exhausts regarding duct size, length, and construction standards. A maximum length of 25' has been established based upon a compilation of appliance manufacturers' recommendations. Bends reduce the length allowed but there are exterior mounted powered exhausts available. The local code should be checked for approvals. Most dryers exhaust approximately 150 to 200 cfm of air. The IRC requires makeup air provisions if dryers exhaust more than 200 cfm. With bath exhaust fans commonly exhausting 50 cfm of air, and range hoods 150 cfm, adding a clothes dryer exhaust may cause an assortment of problems, such as backdrafting of combustion appliances or fireplaces. Bath and kitchen exhausts might not exhaust during dryer operation.

ADVANTAGES: Can ensure fire safety with dryer use; improves indoor air quality; reduces lint and moisture inside the home.

DISADVANTAGES: May induce backdrafting of combustion appliances and fireplaces; may inhibit function of other exhausts in the home.

2. INSTALL A NEW EXHAUST FOR A RANGE.

Range exhausts typically are not code required, relying on windows for exhaust or non-venting filters for cleaning air. Range exhausts are recommended for indoor air quality and safety issues, particularly for gas ranges, as emissions of carbon monoxide, nitrous oxide, and others are present. Fouled burners can produce dangerous levels of benzene, indicated by a yellow flame. Moisture is a product of gas combustion as well, with a gallon of moisture released per 100,000 Btu/hr input (1/8 gallon per hour per average burner). Kitchen exhausts can be recirculating or circulating. Recirculating "exhaust" hoods do not exhaust and move approximately 40 cfm of air through a filter then back to the kitchen. Filters are either charcoal or activated carbon coated fiber, and require maintenance. Circulating exhausts vary from 150 cfm average two-speed hoods to downdraft exhausts of 500 cfm or more. Manufacturers provide similar duct openings so equipment can be replaced (typically 3 1/4" x 10" or 7" round). Duct length is critical and manufacturers' recommendation should be followed. Smooth metal duct material is preferred over flexible metal. An equivalent length adjustment must be made for flex.

ADVANTAGES: Better indoor air quality; mitigates fire hazard.

DISTADVANTAGES: Recirculating hoods do not address combustion products and are not recommended.

FURTHER READING

1996 ASHRAE Handbook - HVAC Systems and Equipment, ASHRAE, Atlanta, GA, 1996.

Domestic Oil Burners, Charles A. Burkhardt, New York: McGraw-Hill, 1961.

E Source Technology Atlas Series: Residential Appliances, E Source, Inc., Boulder, CO, 80302, 303-440-8500, 1996, www.esource.com.

National Fuel Gas Code (NFPA 54), International Approval Services, Cleveland OH 44131, 1996.

FIRE PROTECTION SYSTEMS

ESSENTIAL KNOWLEDGE

According to the National Fire Protection Association (NFPA), there were 406,500 residential fires and 3,360 deaths in the U.S. in 1997. Domestic fires are low probability but high consequence events. Experts indicate that most fires occur in kitchens, family/living rooms, and bedrooms, with highest loss of life in bedrooms and family/living rooms. Fires reportedly burn hotter and faster than 25 years ago because of newer materials in home furnishings.

This Old House magazine recommends adding sprinkler heads during rehab to water systems—a “some protection is better than none” philosophy. However, fire protection engineers say an added system may not perform adequately because there are no hydraulic calculations to verify that the system will work. No valves or alarms are available to tell when the sprinklers might accidentally fail. A loop is needed with sprinkler heads so that standing water in the pipes will not be a concern—potable water that does not circulate can become contaminated. The Director of Operation Life Safety of the International Association of Fire Chiefs suggests adding fire sprinklers to various areas rehabed, essentially adding a system on an “installment plan” basis. Other professionals take an “all or nothing” approach to sprinkler systems. Adding an automatic fire sprinkler system can add to life safety and property protection. Automatic fire sprinkler systems are required in some rehab construction in certain jurisdictions. The local code should be consulted.

NFPA Section 13D governs residential sprinkler systems for one- and two-family construction. Residential systems are relatively new with NFPA 13D, adopted in 1980. Complex automatic fire protection systems are commonly installed in commercial, institutional, and high-rise construction. Residential systems are designed to be less complex. Life safety is the top priority in residential applications, compared to saving property in commercial systems. Still, requirements are deemed too extreme and costly by many. Opponents feel more effective solutions could be enacted. NFPA 13D requires sprinklers in most rooms with flows to allow occupants 10 minutes escape time. The multipurpose system combining plumbing and fire sprinklers are newly approved by NFPA and could be considered. Insurance companies may provide a 5% to 20% yearly insurance rebate to homeowners with sprinkler systems. Canadian insurers may provide a 35% to 40% rebate.

Automatic fire sprinkler systems are designed to provide minimum water flow from heads for a specified escape time. NFPA 13D requires at least one automatic water supply. For homes not on a public water system, a captured water supply large enough for a 10-minute flow from two heads is required. Pools, tanks (elevated or with electric pumps), or tanks pressurized with nitrogen propellant may be used.

Residential sprinklers are separate “wet” systems, compared to wet or dry standpipe systems found in commercial construction. System supply configurations and connections vary in type and complexity and are usually determined by local code. NFPA 13D requires sprinklers in most rooms, except baths, closets, attics, and garages. Heads in non-habitable spaces provide a system with better coverage, but this is more difficult and costly, particularly in rehab work. Wet systems also need protection for freezing temperatures. A fire sprinkler professional, familiar with the local code requirements, should design the system.

Piping materials include welded and seamless steel, wrought steel, copper, and chlorinated polyvinyl chloride (CPVC) and polybutylene (PB). All are common materials used in residential construction. Copper can be used in any area, but CPVC must be used in concealed areas or adjacent to smooth ceilings. CPVC fire sprinkler pipe is a different product than water supply pipe with different code approvals, and the two cannot be combined in most cases. Both can be used with the same fittings but

have varying wall thicknesses. For example, BF Goodrich BlazeMaster CPVC has pipe wall thickness of SDR 13.5 IPS vs. Flow Guard Gold with SDR 11 CTS.

PEX cross-linked polyethylene, multipurpose tubing system for sprinklers has been submitted for UL approval, (approval appears likely), which would lower the 175 psi pressure requirement to 130. Smaller pipe runs, 1/2" vs. 3/4" or 1" would be featured with multiple service connections to each sprinkler head. The material would be a very cost-effective and easy product to install in rehabs. Check with your local code official.

Sprinkler heads vary in design and type. They can be ceiling or side wall mounted, concealed or exposed, and in metallic or prepainted finishes. Quick-response residential sprinkler heads contain a fusible link, pellet or frangible glass bulb. All must be nationally listed and approved. There are many heads available with widely ranging performance ratings (k factor). Coverage from 144 sf to 400 sf per head is possible depending on available flow rates and system pressure. There is a Consumer Products Safety Commission national action filed along with various suits against Central's Omega sprinkler heads. The heads when tested failed to work at the designated pressure, but most worked at higher pressures. If the rehab project includes these heads the International Association of Fire Chiefs recommends you have Omega heads removed and replaced.

Other system elements include a riser and components that control and monitor for the flow of water to the system. The riser components may vary depending on design and code requirements. Typically, they consist of a check valve that lets water flow in only one direction, a pressure gauge, a pressure relief circuit and drain, a flow switch, and a test valve. The riser is connected to the supply. If the water supply is not public, a tank, pond, or source other than a well will be needed. Self-contained systems are available with electric pumps or pneumatic pressure systems.

If running distribution piping within finished walls is not possible, DecoShield makes a UL listed cover and support system. The product was designed for surface mounting retrofit systems in existing buildings and would be appropriate for most rehabs (Fig. 1).



FIGURE 1

DECOSHIELD SYSTEM

TECHNIQUES, MATERIALS, TOOLS

1. INSTALL A STAND-ALONE RESIDENTIAL SPRINKLER SYSTEM.

The stand-alone system is separate from a house's water distribution system and is the most common. A main control valve from the water source to the domestic and fire systems, pressure gauges, check valves, water flow detectors, and drain and test connections are typical.

ADVANTAGES: System water flow activates an alarm; all codes approve; can be connected to fire station; more control of system (flushing and maintenance).

DISADVANTAGES: Can be deactivated by accident; requires more materials and labor; more difficult for rehab.

2. INSTALL A MULTIPURPOSE RESIDENTIAL SPRINKLER SYSTEM.

NFPA issued a Technical Interim Amendment on October 28, 1998 approving multipurpose or combined systems for Section 13D. This means the fire sprinkler and domestic water distribution system can be combined. Most plumbing codes prohibit such systems, but Highland Springs, California and Dupont, Washington are two of many locales that allow them.

ADVANTAGES: Lower cost than stand-alone systems; cannot be deactivated accidentally; reduced materials and labor; easier to install.

DISADVANTAGES: Does not include an alarm; some plumbing codes do not allow; contaminated water is possible without loops in the system; future additions to the house's water system (i.e., water softeners and backflow prevention) could hurt calculated effectiveness.

3. INSTALL A COPPER PIPED SYSTEM.

Copper has been in use for sprinklers since the 1930s and remains the most popular piping material for stand-alone and multipurpose systems. Approval of alternative materials that cost less and are easier to install might change the use of copper piping. The integral soldering fitting described in Section 12 can speed construction.

ADVANTAGES: Code-approved in any installation; commonly used in other plumbing systems; relatively easy installation; fabricated by soldering or brazing using conventional equipment or electric resistance tools; compact within thin walls; tees can be pulled mechanically.

DISADVANTAGES: Costly; more rigid than plastic; brazing or soldering are potentially dangerous; pipe may be subject to condensation; susceptible to theft.

4. INSTALL A CPVC-PIPED SYSTEM.

CPVC water piping has been used in single-family housing since 1959. A reformulation in the 1990s solved cold weather workability problems. CPVC for fire sprinklers is a different product and was introduced in 1986. Code requires CPVC to be installed behind a thermal barrier in most cases, except with quick response sprinklers in special cases.

ADVANTAGES: Low cost; somewhat flexible; more easily installed with cut and glue/weld fittings; better insulation properties than copper.

DISADVANTAGES: Use limited to specific areas; more support required; transitions needed to other non-PVC sections; chars during fire.

FURTHER READING

Automatic Sprinkler Systems Handbook, Quincy, MA: National Fire Protection Association, 1997.

"The Economics of Fast Response Residential Sprinkler Systems," *Fire Journal*, May 1985.

National Fire Protection Association, Section 13D, "Installation and Sprinkler Systems in One- and Two-Family Dwellings and Manufactured Homes," Quincy, MA, 1996.

"Sprinkler Codes A'Changing," *Journal of Light Construction*, Dec. 1989.

"Sprinkle, Sprinkle Little Star," *This Old House*, Jan. 1998.

PRODUCT INFORMATION

BF Goodrich BlazeMaster, Cleveland, OH 44141; 800-331-1144; www.bfgoodrich.com.

Creative Systems, Inc., DecoShield, Jamesville, WI 53545; 608-757-0717.

Reliable Automatic Sprinkler Co., Mt. Vernon, NY 10552; 800-431-1588; www.reliablesprinkler.com.

APPENDIX

PROFESSIONAL ASSOCIATIONS AND RESEARCH CENTERS

AIR CONDITIONING CONTRACTORS OF
AMERICA (ACCA)
1712 New Hampshire Avenue, NW
Washington, DC 20009
202-483-9370
www.acca.org

AIR CONDITIONING AND REFRIGERATION
INSTITUTE (ARI)
4301 North Fairfax Drive, Suite 425
Arlington, VA 22203
www.ari.org

AMERICAN COUNCIL FOR AN ENERGY-
EFFICIENT ECONOMY (ACEEE)
1001 Connecticut Ave. NW, #535
Washington, DC 20036
202-429-8873
www.aceee.org

AMERICAN GAS ASSOCIATION
400 N. Capitol Street, N.W.
Washington, DC 20001
202-824-7000
www.aga.org

AMERICAN NATIONAL STANDARDS INSTITUTE
11 West 42nd Street, 13th Floor
New York, NY 10036
212-642-4900
www.ansi.org

AMERICAN SOCIETY OF HEATING,
REFRIGERATING, AND AIR-CONDITIONING
ENGINEERS (ASHRAE)
1791 Tullie Circle, NE
Atlanta, GA 30329
404-636-8400
www.ashrae.org

AMERICAN SOCIETY OF PLUMBING
ENGINEERS (ASPE)
3617 Thousand Oaks Blvd., #210
Westlake, CA 91362-3649
805-495-7120
www.aspe.org

AMERICAN SOCIETY OF SANITARY
ENGINEERING (ASSE)
28901 Clemens Road, Suite 100
Westlake, OH 44145
440-835-3040
www.asse-plumbing.org

AMERICAN SOCIETY FOR TESTING AND
MATERIALS (ASTM)
100 Barr Harbor Drive
West Conshohocken, PA 19428
610-832-9500
www.astm.org

BUILDERS HARDWARE MANUFACTURERS
ASSOCIATION
355 Lexington Avenue, 17th Floor
New York, NY 10017
212-661-4261
www.buildershardware.com

BUILDING OFFICIALS & CODE
ADMINISTRATORS (BOCA) International, Inc.
4051 West Flossmoor Road
Country Club Hills, IL 60478-5795
708-799-2300
www.bocai.org

CANADA MORTGAGE AND HOUSING
CORPORATION
Housing Information Center
700 Montreal Road
Ottawa, ON, Canada K1A 0P7
613-748-2367
www.cmhc-schl.gc.ca

CANADIAN STANDARDS ASSOCIATION
178 Rexdale Boulevard
Etobicoke (Toronto), ON M9W1R3
416-747-4000
www.csa.ca

CONSORTIUM FOR ENERGY EFFICIENCY
303 Congress Street, Suite 600
Boston, MA 02210
617-330-9755

CONSTRUCTION SPECIFICATIONS INSTITUTE
99 Canal Center Plaza, Suite 300
Alexandria, VA 22314
703-931-4533
www.csinet.org

EDISON ELECTRIC INSTITUTE
701 Pennsylvania Ave. NW
Washington, DC 20004
202-508-5000
www.eei.org

ELECTRIC POWER RESEARCH INSTITUTE
3412 Hillview Ave.
Palo Alto, CA 94303
800-313-3774
www.epri.com

EVAPORATIVE COOLING INSTITUTE
P.O. Box 3ECI
Las Cruces, NM 88003
505-646-3948

FLORIDA SOLAR ENERGY CENTER (FSEC)
1679 Clearlake Road
Cocoa, FL 32922
407-638-1000
www.fsec.ucf.edu

GAS RESEARCH INSTITUTE
8600 Bryn Mawr Ave.
Chicago, IL 60631
312-399-8100
www.gri.org

GEOHERMAL HEAT PUMP CONSORTIUM, INC.
701 Pennsylvania Ave., N.W.
Washington, D.C. 20004-2696
202-508-5500
www.ghpc.org

GREEN SEAL
1400 16th Street, NW Suite 300
Washington, DC 20036-2215
202-588-8400
www.greenseal.org/

HEARTH PRODUCTS ASSOCIATION
2848 Arden Way, Suite 200
Sacramento, CA 95825
916-974-1188

HOME ENERGY RATING SYSTEMS COUNCIL
1331 H St., NW, Suite 1000
Washington, DC 20005
202-638-3700 (phone)
202-393-5043 (fax)
www.hers-council.org

HOME VENTILATING INSTITUTE
Division of AMCA
30 West University Drive
Arlington Heights, IL 60004
847-394-0150

INTERNATIONAL ASSOCIATION OF PLUMBING
AND MECHANICAL OFFICIALS (IAPMO)
20001 E. Walnut Drive South
Walnut, CA 91789-2825
909-595-8449
www.iapmonet.ort

INTERNATIONAL CODE COUNCIL
5203 Leesburg Pike, Suite 708
Falls Church, VA 22041
703-931-4533
www.intlcode.org

INTERNATIONAL GROUND SOURCE HEAT
PUMP ASSOCIATION
490 Cordell South
Oklahoma State University
Stillwater, OK 74078
800-626-4747

**INTERNATIONAL REMODELING
CONTRACTORS ASSOCIATION**

1 Regency Drive
Bloomfield, CT 06002
800-937-4722

INTERNATIONAL STANDARDS ORGANIZATION

1, rue de Varembe
Case postale 56
CH-1211 Gene've 20, Switzerland
41-22-749-01-11
[http:// iso.ch/welcome.html](http://iso.ch/welcome.html)

**LAWRENCE BERKELEY NATIONAL
LABORATORY**

Building Technologies Program
Energy and Environment Division
Lawrence Berkeley Laboratory, Berkeley, CA
94721
510-486-6844
eandl.lbl.gov/BTP/BTP.html

**MECHANICAL CONTRACTORS ASSOCIATION OF
AMERICA (MCAA)**

1385 Piccard Drive
Rockville, MD 20850-4329
301-869-5800
www.mcaa.org

NAHB REMODLERS COUNCIL

1201 15th Street, NW
Washington, DC 20005
202-822-0212
www.nahb.com/remodelc.html

**NATIONAL ASSOCIATION OF ARCHITECTURAL
METAL MANUFACTURERS**

8 S. Michigan Ave., Suite 1000
Chicago, IL 60603-3305
312-456-5590

**NATIONAL ASSOCIATION OF PLUMBING,
HEATING AND COOLING CONTRACTORS**

180 S. Washington St.
P.O. Box 6808
Falls Church, VA 22040
703-237-8100
www.naphcc.org

**NATIONAL ASSOCIATION OF THE
REMODELING INDUSTRY**

4900 Seminary Road, Suite 320
Arlington, VA 22311
703-575-1100
www.nari.org

NATIONAL FIRE PROTECTION ASSOCIATION

1 Batterymarch Park
Quincy, MA 02269-9101
800-344-3555

NATIONAL PROPANE GAS ASSOCIATION

1600 Eisenhower Lane, Suite 100
Lisle, IL 60532
708-515-0600
www.propanegas.com

NATIONAL RENEWABLE ENERGY LABORATORY

1617 Cole Boulevard
Golden, CO 80401
303-275-3000
www.nrel.gov

NATIONAL TECHNICAL INFORMATION SERVICE

US Department of Commerce
www.fedworld.gov/ntis/ntishome.html

OAK RIDGE NATIONAL LABORATORY

Building Envelope Systems and Materials
P.O. Box 2008
Oak Ridge, TN 37831-6070
423-574-4345
www.cad.ornl.gov/kch/demo.html

PLASTICS PIPE INSTITUTE
1801 K St., Suite 600
Washington, DC 20006-1301
202-974-5318
www.plasticpipe.org

PLUMBING MANUFACTURERS INSTITUTE
(PMI)
800 Roosevelt Road
Building C, Suite 20
Glen Ellyn, IL 60137
630-858-9172
www.pmihome.org

RADIANT PANEL ASSOCIATION
P.O. Box 327
Hyrum, UT 84319
801-245-0128

SHEET METAL AND AIR CONDITIONING
CONTRACTORS NATIONAL ASSOCIATION
(SMACNA)
4201 Lafayette Center Drive
Chantilly, VA 22021
703-803-2980

SOUTHFACE ENERGY INSTITUTE
241 Pine Street
Atlanta, GA 30308
404-872-3549
<http://southface.org>

SUSTAINABLE BUILDINGS INDUSTRY COUNCIL
1331 H Street, NW, Suite 1000
Washington, DC 20005
202-628-7400
www.sbicouncil.org

UNDERWRITERS LABORATORIES, INC.
333 Pflingsten Road
Northbrook, IL 60062-2096
847-272-8800
www.ul.com

U.S. DEPARTMENT OF ENERGY
Building Systems and Materials Division
EE-421
1000 Independence Avenue, SW
Washington, DC 20585
202 586 9214
www.doe.gov

U.S. DEPARTMENT OF ENERGY'S
ENERGY EFFICIENCY AND RENEWABLE
ENERGY NETWORK
www.eren.doe.gov

U.S. DEPARTMENT OF ENERGY'S ENERGY
EFFICIENCY AND RENEWABLE ENERGY
CLEARINGHOUSE
P.O. Box 3048
Merrifield, VA 22116
800-363-3732
www.eren.doe.gov/erec/

U.S. DEPARTMENT OF HOUSING
AND URBAN DEVELOPMENT
HUD User
P.O. Box 6091
Rockville, MD 20849
www.huduser.org
800-245-2691

U.S. GOVERNMENT FEDERAL INFORMATION
NETWORK
www.fedworld.gov/

THE REHAB GUIDE

VOLUME ONE: FOUNDATIONS

VOLUME TWO: EXTERIOR WALLS

VOLUME THREE: ROOFS

VOLUME FOUR: WINDOWS AND DOORS

VOLUME FIVE: PARTITIONS, CEILINGS, FLOORS AND STAIRS

VOLUME SIX: KITCHENS & BATHS

VOLUME SEVEN: ELECTRICAL/ELECTRONICS

VOLUME EIGHT: HVAC/PLUMBING

VOLUME NINE: SITE WORK

U.S. Department of Housing and Urban Development
Washington, DC 20410-6000

Official Business
Penalty for Private Use, \$300

August 1999
HUD-DU100C000005956

